

Built With

INTEGRITY



Start to Finish - Flexible Manufacturing gives us complete control over the integrity of our products. From extruding the aluminum to assembling the final product; It all happens under one roof...Ours.

We make the best equipment you can buy. We Guarantee It.

Aluminum Foodservice Catalog

Effective January 1, 2024

We Have Your Buts Covered.

Flexible Manufacturing by New Age Industrial.

It works great, **but** I wish it had...

But I wish it were a different size...

But I need it to...



NEW AGE
INDUSTRIAL
NEW AGE

800-255-0104
NewAgeIndustrial.com

Scan To
Learn More



Custom Products

account for **Over 30%** of our Yearly Sales

Because we have made it **Easy.**

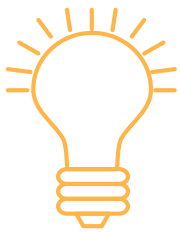

Have An Idea

Come up with a foodservice equipment need that hasn't been filled, that YOU have the solution for.



Write It Down

Describe your new foodservice equipment idea and explain why it is needed.

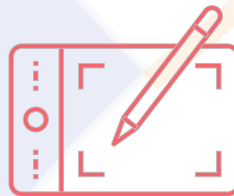

Sketch It Out

Make a simple sketch or line drawing of what the foodservice equipment will look like.



Submit It

Visit our website and submit the form. Be sure to upload your drawing!

NewAgeIndustrial.com

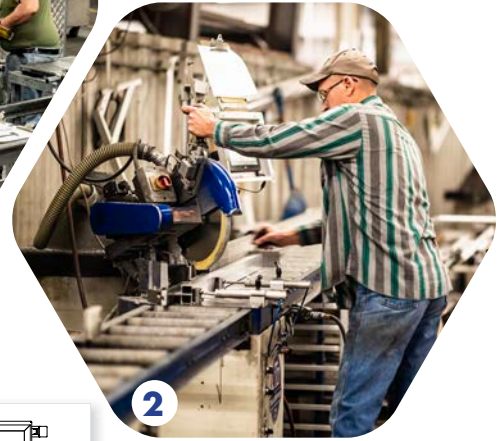
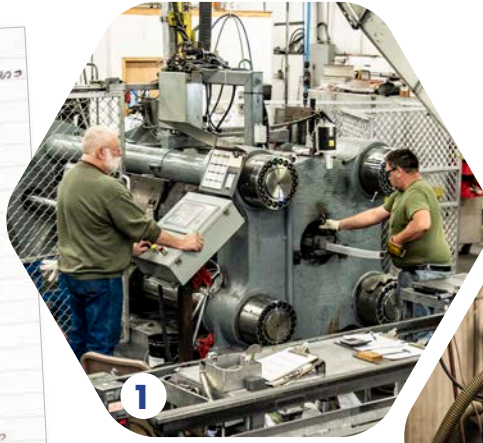
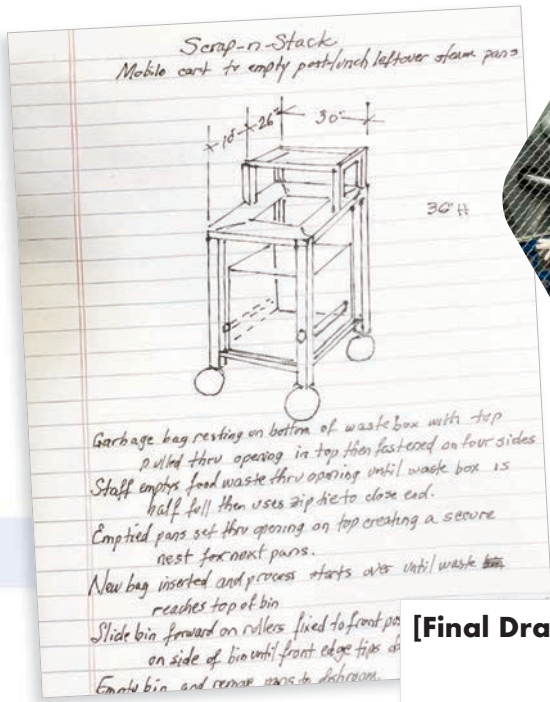

[Final Drawing]

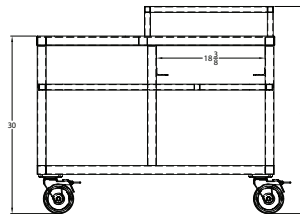
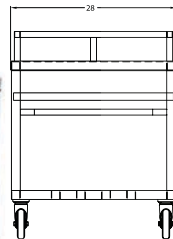
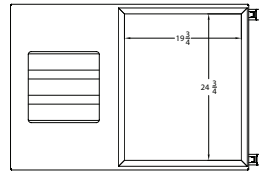

1. Tubing and angles are extruded from Primary Grade Aluminum using our extrusion press.
2. Extrusions are cut to length.
3. Parts are drilled, punched, bent and deburred before they head off to be welded.
4. Pieces are checked and measured carefully before being welded together.
5. Products are showered before final assembly and boxed for shipment.

Watch a video of the complete process.

Table of Contents

CORRECTIONAL

*Most New Age products can be modified for Correctional use.
Please contact the factory for information.*

Cabinets

Enclosed Transport Cabinets	14
Heavy Duty Cabinets	13
Security Cages	50
Utility Cabinets	50

Carts

Mat Carts	68
Utility Carts	24

Racks

Bun Pan Racks	10
Can Racks	33
Covers	2,71
Dunnage Racks	35-36
Insert Racks	9
Mobile Dunnage Racks	35
Stepped-Angle Pan Racks	11-12
Tray Drying Racks	23
Wide-Angle Pan Racks	11-12

Shelving

All Welded Heavy Duty	37
All Welded T-Bar	38

Stands

Equipment Stands	53-54
------------------	-------

Trucks

Platform Trucks	66
-----------------	----

FOODSERVICE

Accessories	71
-------------	----

Baseboard

Cove Baseboard	53
----------------	----

Cabinets

Angle-Ledge Transport Cabinets	15
Clear Door Enclosed Cabinets	13-16
Delivery Cabinets	13-16
Economy "RAC line" Cabinets	14
Enclosed Transport Cabinets	13-16
Heavy Duty Cabinets	13-16
Room Service Cabinets	17
Steamtable Pan Cabinets	14
Universal Adjustable Angle Cabinets	15
Universal Enclosed Cabinets	15
Utility Cabinets	13-16

Carts

2-tier Carts	24,55-57
Airline Catering Carts	20
Banquet Carts	25
Bulk Carts - Frames & Tubs	60

Bussing Carts	32
Carrier Carts	20
Delivery Carts	65-67
Economy "Rac Line" Carts	56-57, 62
Enclosed Carts	13-17
Folding "L" Carts	65
Linen Carts	25
Lug Carts	59-61
Mat Carts	68
Mobile Fry Carts	19
Platter Carts	62-64
Produce Carts	55-58
Queen Marys	25
Room Service Carts	17
School Share Cart	26
Serving Carts	24, 32
Tray Delivery Carts	17-18,25
Tubular Deck Carts	56,65-66
U-Boats	65-67
Universal Carts	24,62
Utility Carts	24,32,55, 65-66

Casters	69-70
---------	-------

Dollies

Angle Dollies	27,29-31
Bowl Dollies	29
Bread Pan Dollies	30
Bun Pan Dollies	30
Chicken Dolly	31
Chill Pac Dollies	27
Chilltray Dollies	27
Crisping Basket Dolly	27
Cup and Glass Dollies	28
Dish Rack Dollies	28
Dough Dollies	32
Food Box Dollies	27
Keg Dolly	48
Lug Dollies	32,59-61
Milk Crate Dollies	31
Mixer Bowl Dolly	29
Mixing Bowl Dolly	29
Oval Tray Dolly	30
Pizza Dough Box Dolly	32
Sheet Pan Dollies	30
Steamtable Pan Dollies	30
Super Dollies	31
Universal Dollies	31
Universal Lug Dollies	61

Miscellaneous

Crisping Baskets	27,58
Drag Hook	30-31
Lugs	61
Tubs	61

Product Options	2,71
-----------------	------

Racks

12"x20"Pan Racks

End Loading - Standard Angle	6
End Loading - Double Deep	4

Half Size - Standard Angle	6
Lifetime Stepped Angle - Roll-In	12
Lifetime Stepped Angle	11
Lifetime Wide Angle - Roll-In	12
Lifetime Wide Angle	11
Refrigerator/Proofer - Wide Angle	3
Side Loading - Standard Angle	6
Steamtable Pan	6
Universal Wide Angle	8,11
Universal Room Service Cart	17
Universal Stepped - Adjustable	9,15
Universal Stepped - Adjustable, Roll-In	9
Universal Stepped - Roll-In	8
Universal Stepped	8
Univ. Stepped Angle Cabinet - Adjustable	15
Wide Angle	8

13"x18" & 14"x18" Pan Racks

Angle Ledge Transport Cabinet	15
Lifetime Stepped Angle - Roll-In	12
Lifetime Stepped Angle	11
Lifetime Wide Angle - Roll-In	12
Lifetime Wide Angle	11
Transport/Retrieval	6
Universal Stepped - Adjustable	9
Universal Stepped - Adjustable, Roll-In	9
Universal Stepped - Roll-in	8
Universal Stepped	8
Univ. Angle Cabinet - Adjustable	15
Wide Angle	8

15"x20" Tray Racks

End Loading - Standard Angle	4
Lifetime Stepped Angle - Roll-In	12
Lifetime Stepped Angle	11
Room Service Cart	17
Side Loading - Double Deep	4
Side Loading - Standard Angle	4
Tray Retrieval	6
Universal Stepped - Adjustable	9,15
Universal Stepped - Adjustable, Roll-In	9
Universal Stepped - Roll-In	8
Universal Stepped	8
Univ. Angle Cabinet - Adjustable	15

Bun Pan Racks

Bakery	1-3,5,7-12,20
Covers	2,71
Economy - All Welded	2,62
Economy - Knocked Down	2
Economy - Refrigerator/Proofer	3
Enclosed Racks	13-16
Full Size - End Loading	1,2,4,5,7-12,64
Full Size - End loading, Knocked Down	1,2
Full Size - Side Loading	1
Full Size - Side Loading, Knocked Down	1
Half Size	1
Insert	9
Lifetime Series	10-13
Nesting "U" Type	7
Nesting "Z" Type	7
Oven	20
Proofer	3,8,9,12



Table of Contents

Refrigerator/Proofer	3,8,9,11-12
Retarder	3,8,9,11-12
Roll-in	3,8,9,12
Sheet Pan	1-5, 7-12
Transport/Retrieval	6
Universal Stepped - Adjustable	9
Universal Stepped - Standard	8
Wide Angle	3,4,8

Can Racks

Economy Can Racks	34
First-In, First-Out Can Racks	34
Half Size Can Racks	33
Heavy Duty Can Racks	33-34
Mobile Can Racks	33-34

Dunnage Racks

Covers	35
Economy RAC Line Dunnage Racks	35
Heavy Duty Dunnage Racks	36
Lifetime Series Dunnage Racks	36
Mobile Dunnage Racks	35

Merchandiser Racks

Display Racks	16,18,22
Folding Merchandiser	22
Mobile Merchandiser	22
Slant Display Rack	16,18

Platter Racks

Double	63
Economy	63
Heavy Duty	64
Standard	63
Universal - Economy	62
Universal - Standard	62

Special Purpose Racks

Airline Catering Racks	20
Combo Racks	5
Display Racks	16,18,22
Donut Screen Racks	18
Food Box Racks	5,62
Glass Racks	28
Keg Racks	47
Oval Tray Racks	4
Pizza Pan Racks	22
Poly Box Racks	5,62
Pot & Pan Racks	19
Retrieval Racks	6
Slant Display Racks	16,18
Transport Racks	6
Trapezoid Tray Racks	6
Tray Delivery Racks	6,13-17
Tray Drying Racks	23
Universal Oval Tray	4,8
Universal Pizza Pan	22
Utility Racks	1-17
Wall Mount Pan Racks	22

Security Cage	50
----------------------------	-----------

Security Fence	49
-----------------------------	-----------

Shelving

Adjustable Shelving

Accessories	43
Adjust-A-Shelf	39-41
Dunnage Style Shelves	39,42
Economy RAC Line Shelves	42
HD Shelves	39,42
Keg Shelving	47
Louvered Shelves	40,42,47
Mobile Shelving	37-42
Posts	43
Pot & Pan Shelving	32
SB Shelves	41
Slatted Shelves	40,42,47
Solid Brute Shelves	41
Solid Reinforced Shelves	41
Solid Shelves	41,42
T-Bar shelves	40,42,47

All Welded Shelving

All Welded Heavy Duty Shelving	37
All Welded T-Bar Shelving	38
All Welded Mobile Shelving	37-38

Cantilever Shelving

Adjustable HD Heavy Duty Shelves	45
Adj. SB Solid Reinforced Shelves	45
Adjustable T-Bar Shelves	45
Free Standing Braces	45
Free Standing Uprights	45
Wall/Ceiling Uprights	46

Wall Shelving

Heavy Duty Shelves	44
Inverted Shelves	44
Marine Edge Shelves	44
Microwave Shelves	44
Solid Wall Shelves	44
Slanted T-Bar Shelves	44
T-Bar Shelves	44
Wall Shelf with Pot Rack	44

Specialty

Corner Guards	53
Merchandising Cart	26
Share Cart	26

Stands

Cooking Equipment Stands	53-54
Counter Top Equipment Stands	1,4,53-54
Equipment Stands	21,53-54
Heavy Duty Stands	21,53-54
Mixer Stands-Mobile	21,53-54
Sandwich Rails	54
Slicer Stands - Mobile	21
Stainless Steel Top Stands	1,4,53
Utility Stands	1,4,21,53-54

Tables

Accessories	52
-------------------	----

Boat Racks	52
Heavy Duty Tables	51
Meat Cutting Tables	51
Poly Top Tables	51
Prep Tables	51
Stainless Steel Top Tables	51
Utility Tables	51

Trucks

Boxed Beef Truck	67
Bulk Carts - Frames & Tubs	60
Deck Trucks	66
Diamond Deck Trucks	66
Folding Trucks	65-66
Heavy Duty Stock Trucks	56,67
Low Boy Stock Trucks	65
Platform Trucks	66
Queen Marys	25
Transport	65-67
Tray Trucks	1-20
U-Boats	65-67
Uni-T Trucks	67
Utility Trucks	24

HEALTHCARE

Accessories	2,71
--------------------------	-------------

Baseboard

Cove Baseboard	53
----------------------	----

Cabinets

Angle-Ledge Transport Cabinets	15
Clear Door Enclosed Cabinets	13-16
Delivery Cabinets	13-16
Economy "RAC line" Cabinets	14
Enclosed Transport Cabinets	13-16
Heavy Duty Cabinets	13-16
Room Service Cabinets	17
Universal Adjustable Angle Cabinets	15
Universal Enclosed Cabinet	15
Utility Cabinets	13-16

Carts

2-Tier Carts	24,55-57
Bulk Carts - Frames & Tubs	60
Health Care Carts	6,12,17, 25
Linen Carts	25
Lug Carts	59-61
Mat Carts	68
Platter Carts	62-64
Queen Marys	25
Room Service Carts	17
Serving Carts	24, 32
Tray Delivery Carts	17-18,25
Tubular Deck Carts	56,65-67
Universal Carts	24,62
Utility Carts	24,32,55

Table of Contents

HEALTHCARE - Cont.

Casters 69-70

Dollies

Angle Dollies	27,29-31
Bowl Dollies.....	29
Bread Pan Dollies	30
Bun Pan Dollies.....	30
Chill Pac Dolly.....	27
Chilltray Dolly	27
Cup and Glass Dollies.....	28
Dish Rack Dollies.....	28
Food Box Dollies.....	27
Lug Dollies	32,59-61
Milk Crate Dollies	31
Mixer Bowl Dollies.....	29
Mixing Bowl Dollies.....	29
Oval Tray Dolly.....	30
Sheet Pan Dollies.....	30
Steamtable Pan Dolly.....	30
Super Dollies.....	31
Universal Dollies	31
Universal Lug Dollies	58

Miscellaneous

Drag Hook.....	30-31
Lugs	61
Tubs	60

Product Options 2,71

Racks

12"x20" Pan Racks

End Loading - Standard Angle.....	6
End Loading - Double Deep	4
Half Size - Standard Angle	6
Lifetime Stepped Angle - Roll-In.....	12
Lifetime Stepped Angle	11
Lifetime Wide Angle - Roll-In	12
Lifetime Wide Angle.....	11
Refrigerator/Proofer - Wide Angle.....	3
Side Loading - Standard Angle.....	6
Steamtable	6
Universal Wide Angle	8,11
Universal Room Service Cart	17
Universal Stepped - Adjustable	9,15
Universal Stepped - Adjustable, Roll-In.....	9
Universal Stepped - Roll-In.....	8
Universal Stepped	8
Univ. Stepped Angle Cabinet - <i>Adjustable</i>	15
Wide Angle	8

13"x18" & 14"x18" Pan Racks

Angle Ledge Transport Cabinet.....	15
Lifetime Stepped Angle - Roll-In	12
Lifetime Stepped Angle.....	11
Lifetime Wide Angle - Roll-In	12
Lifetime Wide Angle.....	11
Transport/Retrieval	6
Universal Room Service Cart	16

Universal Stepped - Adjustable	9
Universal Stepped - Adjustable, Roll-In.....	9
Universal Stepped - Roll-In.....	8
Universal Stepped	8
Univ. Stepped Angle Cabinet - <i>Adjustable</i>	15
Wide Angle	8

15"x20" Tray Racks

End Loading - Standard Angle.....	4
Lifetime Stepped Angle - Roll-In	12
Lifetime Stepped Angle.....	11
Room Service Cart	17
Side Loading - Double Deep	4
Side Loading - Standard Angle	4
Tray Retrieval	6
Universal Stepped - Adjustable	9,15
Universal Stepped - Adjustable, Roll-In.....	9
Universal Stepped - Roll-In.....	8
Universal Stepped	8
Univ. Stepped Angle Cabinet - <i>Adjustable</i>	15

Bun Pan Racks

Bakery	1-3,5,7-12,20
Covers	2,71
Economy - All Welded.....	2,62
Economy - Knocked Down	2
Economy - Refrigerator/Proofer.....	3
Enclosed.....	13-16
Full Size - <i>End Loading</i>	1,2,4,5,7-12,63
Full Size - <i>End loading, Knocked down</i>	1,2
Full Size - Side Loading.....	1
Full Size - Side Loading, <i>Knocked down</i>	1
Half Size	1
Insert.....	9
Lifetime Series	10-13
Nesting "U" type.....	7
Nesting "Z" type.....	7
Oven	20
Proofer.....	3,8,9,11-12
Refrigerator/Proofer	3,8,9,12
Retarder.....	3,8,9,11-12
Roll-In	3,8,9,12
Sheet Pan	1-5, 7-12
Transport/Retrieval	6
Universal Stepped - Adjustable	9,15
Universal Stepped - Standard	8
Wide Angle	3,4,8

Can Racks

Economy Can Racks	34
First-In, First-Out Can Racks.....	34
Half Size Can Racks.....	33
Heavy Duty Can Racks.....	33-34
Mobile Can Racks	33-34

Dunnage Racks

Covers	35
Economy RAC Line Dunnage Racks.....	35
Heavy Duty Dunnage Racks.....	36
Lifetime Series Dunnage Racks	36
Mobile Dunnage Racks	35

Merchandise Racks

Display Racks.....	16,18
Slant Display Rack	16,18

Platter Racks

Double	63
Economy.....	63
Heavy Duty	64
Standard	63
Universal - Economy.....	62
Universal - Standard.....	62

Special Purpose Racks

Combo Racks	5
Display Racks	16,18
Food Box Racks	5,62
Glass Racks	28
Oval Tray Racks	4
Poly Box Racks	5,62
Pot & Pan Racks	19
Retrieval Racks	6
Slant Display Racks.....	16,18
Transport Racks	6
Tray Delivery Racks.....	6,13
Tray Drying Racks	23
Universal Oval Tray Racks	4,8
Utility Racks.....	1-17
Wall Mount Pan Racks	22

Shelving

Adjustable Shelving

Adjust-A-Shelf.....	39-41
Accessories	43
Dunnage Style Shelves	39,42
Economy RAC Line Shelves.....	42
HD Shelves.....	39,42
Louvered Shelves	40,42,47
Mobile Shelving	37-42
Posts.....	43
Pot & Pan Shelving.....	19
SB Shelves	41
Slatted Shelves.....	40,42,47
Solid Brute Shelves	41
Solid Reinforced Shelves	41
Solid Shelves.....	41,42
T-Bar Shelves	40,42,47

All Welded Shelving

All Welded Heavy Duty Shelving.....	37
All Welded T-Bar Shelving	38
All Welded Mobile Shelving	37-38

Cantilever Shelving

Adjustable HD Heavy Duty Shelves	45
Adjustable SB Solid Reinforced Shelves.....	45
Adjustable T-Bar Shelves	45
Free Standing Braces	45
Free Standing Uprights.....	45
Wall/Ceiling Uprights	46



Table of Contents

Wall Shelving

Heavy Duty Shelves	44
Inverted Shelves	44
Marine Edge Shelves	44
Microwave Shelves	44
Solid Wall Shelves	44
Slanted T-Bar Shelves	44
T-Bar Shelves	44
Wall Shelf with Pot Rack	44

Specialty

Corner Guards	53
---------------------	----

Stands

Cooking Equipment Stands	53-54
Counter Top Equipment Stands	1,4,53-54
Equipment Stands	21,53-54
Heavy Duty Stands	21,53-54
Mixer Stands-Mobile	21,53-54
Sandwich Rails	54
Slicer Stands - Mobile	21
Stainless Steel Top Stands	1,4,53
Utility Stands	1,4,21,53-54

Tables

Accessories	52
Heavy Duty Tables	51
Poly Top Tables	51
Prep Tables	51
Stainless Steel Top Tables	51
Utility Tables	51

Trucks

Bulk Cart - Frames & Tubs	60
Deck Trucks	66
Diamond Deck Trucks	66
Platform Trucks	66
Queen Marys	25
Tray Trucks	1-20

MATERIAL HANDLING

Accessories	71
--------------------------	----

Baseboard

Cove Baseboard	53
----------------------	----

Carts

2-Tier Carts	24,55-57
Bulk Carts - Frames & Tubs	60
HD Multi-Shelf Carts, Stainless Steel	25
HD Multi-Shelf Carts, Aluminum	25
Low Boy Carts	65
Lug Carts	59-61
Mat Carts	68
Picking Carts	55,65-67
Platter Carts	62-64
Stocking Carts	24,55-56,65-67
Tubular Deck Carts	53,56,65-67
U-Boats	65-67
Universal Carts	24,59-60
Utility Carts	24, 55,65-67

Casters	69-70
----------------------	-------

Dollies

Lug Dollies	32,59-61
Super Dollies	31
Universal Dollies	31
Universal Lug Dollies	61

Miscellaneous

Drag Hook	30-32
Lugs	61
Tubs	60
Product Options	71

Racks

Carrier Cart	20
Combo Racks	5
Covers	2,71
Insert Rack	9
Poly Box Storage Rack	5
Slant Display Rack	16
Transport/Retrieval	6
Universal Stepped	8
Universal Stepped - Adjustable	9
Universal Stepped - Roll-In	8
Wide Angle	8

Platter Racks

Double Platter Racks	63
Economy Platter	63
Heavy Duty	64
Standard Platter Racks	63
Universal - Economy	62
Universal - Standard	62

Special Purpose Racks

Carrier Racks	20
Combo Racks	5
Display Racks	16,18,22
Oval Tray Racks	4
Poly Box Racks	5,62
Retrieval Racks	6
Slant Display Racks	16
Transport Racks	6
Universal Oval Tray Racks	4,8
Utility Racks	5,6,8,9,16,20

Security Cage	50
----------------------------	----

Security Fence	49
-----------------------------	----

Shelving

Adjustable Shelving

Adjust-A-Shelf	39-41
Accessories	43
Dunnage Style Shelves	39,42
Economy RAC Line Shelves	42
HD Shelves	39,42

Louvered Shelves	40,42,47
Mobile Shelving	37-42
Posts	43
SB Shelves	41
Slatted Shelves	40,42,47
Solid Brute Shelves	41
Solid Reinforced Shelves	41
Solid Shelves	41,42
T-Bar Shelves	40,42,47

All Welded Shelving

All Welded Heavy Duty Shelving	37
All Welded T-Bar Shelving	38
All Welded Mobile Shelving	37-38

Cantilever Shelving

Adjustable HD Heavy Duty Shelves	45
Adjustable SB Solid Reinforced Shelves	45
Adjustable T-Bar Shelves	45
Free Standing Braces	45
Free Standing Uprights	45
Wall/Ceiling Uprights	46

Wall Shelving

Heavy Duty Shelves	44
Inverted Shelves	44
Marine Edge Shelves	44
Solid Wall Shelves	44
T-Bar Shelves	44
Wall Shelf with Pot Rack	44

Specialty

Corner Guards	53
---------------------	----

Stands

Equipment Stands	53-54
Heavy Duty Stands	53-54
Stainless Steel Top Stands	53-54
Utility Stands	53-54

Tables

Accessories	52
Boat Racks	52
Heavy Duty Tables	51
Meat Cutting Tables	51
Poly Top Tables	51
Prep Tables	51
Stainless Steel Top Tables	51
Utility Tables	51

Trucks

Boxed Truck	67
Bulk Carts - Frames & Tubs	60
Deck Trucks	66
Diamond Deck Trucks	66
Folding Trucks	65-66
Folding Platform Trucks	65-66
Heavy Duty Stock Trucks	56,67
Low Boy Stock Trucks	65
Platform Trucks	66
Tiered Transport Trucks	25

Table of Contents

MATERIAL HANDLING- Cont.

Transport.....	65-67
U-Boats.....	65-67
Uni-T Trucks.....	67
Utility Trucks.....	65-66

SUPERMARKET

Accessories	2,71
--------------------------	------

Baseboard

Cove Baseboard	53
----------------------	----

Cabinets

Angle-Ledge Transport Cabinets	15
Clear Door Enclosed Cabinets.....	13-16
Delivery Cabinets.....	13-16
Economy "RAC Line" Cabinets	14
Enclosed Transport Cabinets.....	13-16
Heavy Duty Cabinets	13-16
Universal Adjustable Angle Cabinets	15
Universal Enclosed Cabinets	15
Utility Cabinets	13-16

Carts

2-Tier Carts	24,55-57
Bulk Carts - Frames & Tubs.....	60
Floral Cart	55
Low Boy Carts.....	65
Lug Carts.....	59-61
Mat Carts.....	68
Picking Carts.....	55-56,65-67
Platter Carts	62-64
Produce Carts	55-58
Produce Merchandiser.....	58
Stocking Carts.....	55-57,65-67
Tubular Deck Carts	55-57,65-67
U-Boats	65-67
Universal Carts.....	24,62
Utility Carts.....	24,32,55,65-66

Casters	69-70
----------------------	-------

Dollies

Angle Dollies	27,29-31
Bread Pan Dollies	30
Chicken Dolly	31
Food Box Dollies	27
Lug Dollies	32,59-61
Milk Crate Dollies	31
Mixer Bowl Dolly	29
Mixing Bowl Dollies	29
Oval Tray Dolly	30
Sheet Pan Dollies.....	30
Steamtable Pan Dolly.....	30
Super Dollies.....	31
Universal Lug Dollies	61

Miscellaneous

Drag Hook.....	30-32
Lugs	61
Tubs	60

Product Options	2,71
------------------------------	------

Racks

12"x20" Pan Racks

End Loading - Standard Angle.....	6
End Loading - Double Deep	4
Half Size - Standard Angle	6
Lifetime Stepped Angle - Roll-In	12
Lifetime Stepped Angle.....	11
Lifetime Wide Angle - Roll-In	12
Lifetime Wide Angle	11
Refrigerator/Proofer - Wide Angle.....	3
Side Loading - Standard Angle.....	6
Steamtable Rack	6
Universal Wide Angle	8,11
Universal Stepped - Adjustable	9
Universal Stepped - Adjustable, Roll-In	9
Universal Stepped - Roll-In.....	8
Universal Stepped	8
Univ. Stepped Angle Cabinet - Adjustable	15
Wide Angle	8

13"x18" & 14"x18" Pan Racks

Angle Ledge Transport Cabinet.....	15
Lifetime Stepped Angle - Roll-In	12
Lifetime Stepped Angle.....	11
Lifetime Wide Angle - Roll-In	12
Lifetime Wide Angle	11
Transport/Retrieval	6
Universal Stepped - Adjustable	9
Universal Stepped - Adjustable, Roll-In	9
Universal Stepped - Roll-In.....	8
Universal Stepped	8
Univ. Stepped Angle Cabinet - Adjustable	15
Wide Angle	8

15"x20" Tray Racks

End loading - Standard Angle.....	4
Lifetime Stepped Angle - Roll-In	12
Lifetime Stepped Angle.....	11
Side Loading - Double Deep	4
Side Loading - Standard Angle.....	4
Tray Retrieval	6
Universal Stepped - Adjustable	9,15
Universal Stepped - Adjustable, Roll-In	9
Universal Stepped - Roll-In.....	8
Universal Stepped	8
Univ. Angle Cabinet - Adjustable.....	15

Bun Pan Racks

Bakery	1-2,5,7,10-11,20
Covers	2,71
Economy - All Welded.....	2,64
Economy - Knocked Down	2
Economy - Refrigerator/Proofer.....	3

Enclosed Racks.....	13-16
Full Size - End Loading	1,2,4,5,7,8,9,10,11,64
Full Size - End loading, Knocked Down	1,2
Full Size - Side Loading.....	1
Full Size - Side Loading, Knocked Down	1
Half Size	1
Insert.....	9
Lifetime Series.....	10-13
Nesting "U" Type.....	7
Nesting "Z" Type	7
Oven	20
Proofer	3,8,9,12
Refrigerator/Proofer.....	3,8,9,12
Retarder.....	3,8,9,12
Roll-In	3,8,9,12
Sheet Pan	1-5, 7-12
Transport/Retrieval	6
Universal Stepped - Adjustable	9
Universal Stepped - Standard	8
Wide Angle	3,4,8

Can Racks

Economy Can Racks	34
First-In, First-Out Can Racks.....	34
Half Size Can Racks.....	33
Heavy Duty Can Racks.....	33-34
Mobile Can Racks	33

Dunnage Racks

Covers	35
Economy RAC Line Dunnages.....	35
Heavy Duty Dunnage	36
Lifetime Series Dunnage	36
Mobile Dunnage	35

Merchandiser Racks

Display	16,22,58
Folding Merchandiser	58
Mobile Merchandiser	58
Slant Display.....	16

Platter Racks

Double Platter.....	63
Economy.....	63
Heavy Duty	64
Standard	63
Universal - Economy.....	62
Universal - Standard.....	62

Special Purpose Racks

Catering Racks	20
Combo Racks	5
Display Racks.....	16,18,22
Food Box Racks	5,62
Glass Racks	28
Oval Tray Racks	4
Pizza Pan Racks	22
Poly Box Racks	5,62
Pot & Pan Racks	19
Slant Display Racks.....	16,18



Table of Contents

Transport Racks 6
 Tray Drying Racks 23
 Universal Oval Tray 4,8
 Utility Racks 1-17
 Wall Mount Pan Racks 22

Security Cage 50

Security Fence 49

Shelving

Adjustable Shelving

Accessories 43
 Adjust-A-Shelf 39-41
 Dunnage Style Shelves 39,42
 Economy RAC Line Shelves 42
 HD Shelves 39,42
 Louvered Shelves 40,42,47
 Mobile Shelving 37-42
 Posts 43
 Pot & Pan Shelving 19
 SB Shelves 41
 Slatted Shelves 40,42,47
 Solid Brute Shelves 41
 Solid Reinforced Shelves 41
 Solid Shelves 41,42
 T-Bar Shelves 40,42,47

All Welded Shelving

All Welded Heavy Duty Shelving 37
 All Welded T-Bar Shelving 38
 All Welded Mobile Shelving 37-38

Cantilever Shelving

Adjustable HD Heavy Duty Shelves 45
 Adjustable SB Solid Reinforced Shelves 45
 Adjustable T-Bar Shelves 45
 Free Standing Braces 45
 Free Standing Uprights 45
 Wall/Ceiling Uprights 46

Wall Shelving

Heavy Duty Shelves 44
 Inverted Shelves 44
 Marine Edge Shelves 44
 Microwave Shelves 44
 Solid Wall Shelves 44
 Slanted T-Bar Shelves 44
 T-Bar Shelves 44
 Wall Shelf with Pot Rack 44

Specialty

Corner Guards 53

Stands

Cooking Equipment Stands 53-54
 Counter Top Equipment Stands 1,21,53-54
 Equipment Stands 21,53-54
 Heavy Duty Stands 21,53-54
 Mixer Stands-Mobile 21,53-54
 Sandwich Rails 54
 Slicer Stands - Mobile 21
 Stainless Steel Top Stands 1,53-54
 Utility Stands 21,53-54

Tables

Accessories 52
 Boat Racks 52
 Heavy Duty Tables 51
 Meat cutting Tables 51
 Poly Top Tables 51
 Prep Tables 51
 Stainless Steel Top Stands 50
 Utility Tables 51

Trucks

Boxed Beef Truck 67
 Bulk Carts - Frames & Tubs 60
 Deck Trucks 66
 Diamond Deck Trucks 66
 Folding Platform Trucks 66
 Folding Trucks 65-66
 Heavy Duty Stock Trucks 56,67
 Low Boy Stock Trucks 65
 Multi-Shelf Trucks 25
 Platform Trucks 66
 Transport 65-67
 Tray Trucks 1-20
 U-Boats 65-67
 Uni-T Trucks 67
 Utility Trucks 65-66



**For Current
 Product Lead Times**
 visit our website at

NewAgeIndustrial.com

1. Search
 Type in Model Number



2. Check Column



Pan Racks



1311

- All welded aluminum construction — No rivets.
- Units will hold 13" x 18", 14" x 18", and 18" x 26" pans.
- Four, one-inch welds per angle guide.
- Lifetime Guarantee against rust and corrosion, superior strength and durability guaranteed.
- NSF Certified.



▶ 1/2-Size Sheet Pan Rack

Model No.	Size W-H-D	Pan Capacity	Runner Spacing	Top Type	Ship Lbs.	List Price
Under-Counter Size - End Loading						
1313	20 ³ / ₈ " x 32 ¹ / ₄ " x 26"	8	3"	Stainless	36	\$ 1,020
1314	20 ³ / ₈ " x 32 ¹ / ₄ " x 26"	8	3"	None	27	\$ 762
Bakery 1/2-Size with Poly Top - End Loading						
95958	20 ³ / ₈ " x 33 ³ / ₈ " x 26"	5	4 1/2"	Poly	36	\$ 940
Regular 1/2-Size - End Loading						
1311	20 ³ / ₈ " x 38" x 26"	10	3"	Stainless	42	\$ 1,021
1312	20 ³ / ₈ " x 38" x 26"	10	3"	None	30	\$ 765
92096	20 ³ / ₈ " x 38" x 26"	10	3"	Poly	42	\$ 998
1321	20 ³ / ₈ " x 38" x 26"	6	5"	Stainless	35	\$ 899
1322	20 ³ / ₈ " x 38" x 26"	6	5"	None	24	\$ 639
Replacement Top - Not NSF Certified						
45106	20 ³ / ₈ " x 26" - Stainless Steel				11	\$ 260
45256	20 ³ / ₈ " x 26" - Aluminum				4	\$ 158

Four 5" stem type swivel casters.

OPTIONS: Options may not be NSF Certified. Contact the factory.
 "CL(A)", "MD", "PS", "VB" - see page 71 for details.



All sheet pan racks quoted hold USA standardized 18 x 26" sheet pans (17⁷/₈ x 25⁷/₈" actual). We are not responsible for pans that do not meet the industry standard, which may not fit our racks.

▶ Sheet Pan Rack - Heavy Duty



1461



1331S

- All units accommodate 13" x 18", 14" x 18", and 18" x 26" pans.
- Welded reinforced gussets keep the rack square.
- Knocked Down Racks are not suitable for bagel applications.
- Lifetime Guarantee against rust and corrosion, superior strength and durability guaranteed.
- NSF Certified.



Model No.	Size W-H-D	Pan Capacity	Runner Spacing	Ship Lbs.	List Price
3/4-Size End Loading Rack					
1361	20 ³ / ₈ " x 60 ³ / ₈ " x 26"	17	3"	48	\$1,036
End Loading Rack					
1461*	20 ¹¹ / ₁₆ " x 69 ³ / ₄ " x 26"	38	1 1/2"	56	\$1,196
1330	20 ³ / ₈ " x 69 ³ / ₄ " x 26"	30	2"	70	\$1,285
1331	20 ³ / ₈ " x 69 ³ / ₄ " x 26"	20	3"	56	\$1,078
1332	20 ³ / ₈ " x 69 ³ / ₄ " x 26"	15	4"	52	\$1,036
1333	20 ³ / ₈ " x 69 ³ / ₄ " x 26"	12	5"	48	\$ 899
1334	20 ³ / ₈ " x 69 ³ / ₄ " x 26"	10	6"	43	\$ 836
Side Loading Racks					
1461S*	28 ³ / ₈ " x 69 ³ / ₄ " x 19"	38	1 1/2"	48	\$1,170
1330S	28 ³ / ₈ " x 69 ³ / ₄ " x 19"	30	2"	58	\$1,202
1331S	28 ³ / ₈ " x 69 ³ / ₄ " x 19"	20	3"	50	\$1,031
1332S	28 ³ / ₈ " x 69 ³ / ₄ " x 19"	15	4"	46	\$1,004
1333S	28 ³ / ₈ " x 69 ³ / ₄ " x 19"	12	5"	46	\$ 892
1334S	28 ³ / ₈ " x 69 ³ / ₄ " x 19"	10	6"	46	\$ 823

Four 5" plate type swivel casters.

* #1461 & #1461S Units hold pans by the lip only.

OPTIONS: Options may not be NSF Certified. Contact the factory.

- Standard Unit Options:**
 "CL(B)", "B", "E", "M6", "MD", "VB", "PB", "PP(A)", "PS" - see page 71.
- Knocked Down Unit Options: Not NSF Certified.**
 Knocked Down Units - Add "KD" suffix to model #. (no charge)
 Four 5" stem type swivel casters.
 This option is not available for model #1461, #1461S or #1361.
 "CL(A)", "VB" - see page 71 for details.



All sheet pan racks quoted hold USA standardized 18" x 26" sheet pans (17⁷/₈ x 25⁷/₈" actual). We are not responsible for pans that do not meet the industry standard, which may not fit our racks.

► Sheet Pan Rack - Standard

Model No.	Size W-H-L	Pan Capacity	Runner Spacing	Ship Lbs.	List Price
All-Welded Units - 5" plate type swivel casters.					
7331	20 ³ / ₈ " x 69 ³ / ₄ " x 26"	20	3"	45	\$ 887
Options: Options may not be NSF Certified. Contact the factory. "B", "CL(B)", "PB", "PS", "VB" - see page 71 for details.					
All-Welded Units - 5" stem type swivel casters.					
6330	20 ³ / ₈ " x 69" x 26"	30	2"	50	\$1,034
6331	20 ³ / ₈ " x 69" x 26"	20	3"	38	\$ 782
6333	20 ³ / ₈ " x 69" x 26"	12	5"	33	\$ 707
Options: Options may not be NSF Certified. Contact the factory. "CL(A)", "PS", "VB" - see page 71 for details.					
Knocked Down Units - 5" stem type swivel casters.					
6300	20 ³ / ₈ " x 69" x 26"	30	2"	49	\$ 960
6301	20 ³ / ₈ " x 69" x 26"	20	3"	39	\$ 707
6303	20 ³ / ₈ " x 69" x 26"	12	5"	32	\$ 595
Options: Options may not be NSF Certified. Contact the factory. "CL(A)", "VB" - see page 71 for details.					

- Accommodates 13" x 18", 14" x 18", and 18" x 26" sheet pans.



! All sheet pan racks quoted hold USA standardized 18" x 26" sheet pans (17⁷/₈" x 25⁷/₈" actual). We are not responsible for pans that do not meet the industry standard, which may not fit our racks.

► Sheet Pan Rack Options

See Page 71 For More Details.

"B" - Corner Bumpers (4) - Add "B" suffix to the model #.	\$ 116
"CL" - Caster Locks (2)	
(A) 5" stem type swivel caster (7/16" dia) - Add "CL" suffix to the model #.	\$ 14
(B) 5" plate type swivel caster - Add "CL" suffix to the model #.	\$ 16
"E" - Solid Base - Add "E" suffix to the model #.	\$ 260
"M6" - Caster Upgrade - Add "M6" suffix to the model #.	\$ 418
"MD" - Medical Caster Upgrade - Add "MD" suffix to the model #.	\$ 343
"PB" - Perimeter Bumper - Add "PB" suffix to the model #.	\$ 341
"PP" - Prison Package	
(A) Tamper Resistant Screws - Add "PP" suffix to the model #.	\$ 88
"PS" - Pan Stop - Add "PS" suffix to the model #.	\$ 71
"VB" - Vertical Bumpers (4) - Add "VB" suffix to the model #.	\$ 198
1359 - Rack Cover (Clear, 12 mil) • 23"W x 64"H x 28"D	\$ 325

Options may not be NSF Certified. Contact the factory.



Pan Racks



1337



1336

► Refrigerator/Proofer Rack - Heavy Duty

Model No.	Size W-H-D	Pan Capacity	Runner Spacing	Ship Lbs.	List Price
Standard Refrigerator/Proofer Racks					
1337	20 ³ / ₈ " x 64" x 26"	11	5"	45	\$ 1,095
1338	20 ³ / ₈ " x 64" x 26"	18	3"	55	\$ 1,256
95433*	20 ¹ / ₁₆ " x 64 ¹ / ₂ " x 26"	36	1 ¹ / ₂ "	53	\$ 1,343
Wide-Angle Refrigerator/Proofer Racks — Accepts 18" x 26" or 12" x 20" Pans					
1335	20 ³ / ₈ " x 64" x 26"	18	3"	72	\$ 1,870
1336	20 ³ / ₈ " x 64" x 26"	11	5"	56	\$ 1,513

Four 5" plate type casters; two swivel, two swivel with brake.

* **This Unit Holds Pans By The Lip Only. Not NSF Certified.**

OPTIONS: Options may not be NSF Certified. Contact the factory.

"B", "E", "PB", "PS", "VB" - see page 71 for details.

- Designed to accommodate 13" x 18", 14" x 18", and 18" x 26" pans. - Wide-Angle racks also accommodate 12" x 20" pans.
- Casters are inset, rolling within the perimeter of the base for easy loading and unloading.
- All welded aluminum construction... No rivets to loosen.
- Heavy duty, 5" plate type swivel casters, two with brake.
- Lifetime Guarantee against rust and corrosion.
- NSF Certified.



! All sheet pan racks quoted hold USA standardized 18" x 26" sheet pans (17⁷/₈" x 25⁷/₈" actual). We are not responsible for pans that do not meet the industry standard, which may not fit our racks.



95864

► Refrigerator/Proofer Rack - Standard

Model No.	Size W-H-D	Pan Capacity	Runner Spacing	Ship Lbs.	List Price
95864	20 ³ / ₈ " x 63 ³ / ₁₆ " x 26"	18	3"	35	\$ 790

Four 5" stem type swivel casters.

Options: Options may not be NSF Certified. Contact the factory.

"CL(A)", "PS", "VB" - see page 71 for details.

- Accommodates 13" x 18", 14" x 18", and 18" x 26" sheet pans.
- This rack is ideal for light- to medium-duty food service, bakery, and supermarket applications.
- Heavy duty, extruded angles provide easy product access and selection.

! All sheet pan racks quoted hold USA standardized 18" x 26" sheet pans (17⁷/₈" x 25⁷/₈" actual). We are not responsible for pans that do not meet the industry standard, which may not fit our racks.



▶ Oval Tray Rack

Model No.	Size W-H-D	Tray Capacity	Tray Size	Angle Spacing	Ship Lbs.	List Price
Standard Units - Accepts Various Oval Trays						
NS893	24 $\frac{3}{4}$ " x 69 $\frac{3}{4}$ " x 27 $\frac{1}{2}$ "	10	22" x 26 $\frac{7}{8}$ "	6"	57	\$ 1,164
95681	24 $\frac{3}{4}$ " x 63 $\frac{3}{4}$ " x 27 $\frac{1}{2}$ "	9	22" x 26 $\frac{7}{8}$ "	6"	54	\$ 1,102
95048	26 $\frac{3}{8}$ " x 69 $\frac{3}{4}$ " x 30"	10	23 $\frac{1}{2}$ " x 29"	6"	62	\$ 1,214
Four 5" plate type swivel casters.						
Universal - Accepts various oval trays, 18" x 26" and 12" x 20" pans.						
96058	26 $\frac{1}{2}$ " x 70 $\frac{1}{8}$ " x 30"	10	See Below	6"	99	\$ 2,399
Universal Units (#96058 & #97690) accept oval tray sizes 22$\frac{3}{4}$" x 27$\frac{3}{8}$", 20$\frac{3}{4}$" x 25$\frac{1}{2}$", and 23$\frac{1}{2}$" x 29".						

Four 5" plate type swivel casters.

Options: Options may not be NSF Certified. Contact the factory.

"B", "CL(B)", "M6", "PB", "PS", "VB" - see page 71 for details.

- Handles most oval tray sizes.
- Ideal for serving large parties and banquets.
- Gussets are welded in all corners to prevent "racking".
- Four, one inch welds per angle guide.
- Lifetime Guarantee against rust and corrosion.
- NSF Certified.



95681

96058



▶ 15" x 20" Tray Rack

Model No.	Size W-H-D	Pan Capacity	Runner Spacing	Ship Lbs.	List Price
Side Loading Unit					
NS833	23 $\frac{1}{8}$ " x 69" x 30 $\frac{1}{2}$ "	24	5"	41	\$1,063
End Loading Unit					
NS832	17 $\frac{7}{8}$ " x 69" x 21"	12	5"	32	\$ 887
Side Loading Unit - Double Deep with Stainless Steel Top					
NS834	23 $\frac{1}{8}$ " x 38" x 30"	12	5"	42	\$1,229
Side Loading Unit - Double Deep, No Top					
NS834A	23 $\frac{1}{8}$ " x 38" x 30"	12	5"	30	\$ 769

Four 5" stem type swivel casters.

Options: Options may not be NSF Certified. Contact the factory.

"CL(A)", "E", "MD", "PS", "VB" - see page 71 for details.

52038 Vinyl Cover for #NS832 - Not NSF Certified..... \$ 690
green vinyl cover with (4) zippers

- Specifically designed for 15" x 20" trays.
- Extra gussets are welded in all corners to prevent "racking".
— All welded construction.
- Four, one inch welds per angle guide.
- Lifetime Guarantee against rust and corrosion.
- NSF Certified.



NS834A

NS833



Pan Racks



1481



92052

► Poly Box Storage Rack

Model No.	Size W-H-D	Poly Box Capacity	Runner Spacing	Ship Lbs.	List Price
End Loading - Accepts 18" x 26" or 18" x 13" Poly Food Boxes					
1481	20 ⁷ / ₁₆ " x 70 ¹ / ₄ " x 26"	8	7 ¹ / ₂ "	42	\$ 933
NS648	20 ⁷ / ₁₆ " x 70 ³ / ₄ " x 26"	16	3 ¹ / ₂ "	53	\$ 1,243
92052	20 ⁷ / ₁₆ " x 71 ³ / ₄ " x 26"	12	5"	48	\$ 1,102

Four 5" plate type casters; two swivel, two swivel with brake.

Designed to accommodate 13" x 18" and 18" x 26" poly food boxes, with or without a lid. Compatible with boxes manufactured by Cambro®, Carlisle®, Continental®, or Rubbermaid®.

Rack capacity is determined by the depth of the box.

THESE UNITS WILL NOT HOLD 18" x 26" BUN PANS.

Options: Options may not be NSF Certified. Contact the factory.

"B", "E", "M6", "MD", "PB", "PS", "VB" - see page 71 for details.

- Transport food boxes with one rack.
- Unique "C" channel design holds boxes securely (with or without lid)... Even when pulled partly out.
- **All welded aluminum construction with 5" plate type casters.**
- Lifetime Guarantee against rust and corrosion.
- NSF Certified.



► Poly Box/Sheet Pan Combination Rack

Model No.	Size W-H-D	Pan Capacity	Runner Spacing	Ship Lbs.	List Price
1482	20 ³ / ₈ " x 69 ³ / ₄ " x 26"	11	5"	44	\$ 1,164
1484	20 ³ / ₈ " x 69 ³ / ₄ " x 26"	16	3 ¹ / ₂ "	47	\$ 1,306
1486	20 ³ / ₈ " x 69 ³ / ₄ " x 26"	8	7 ¹ / ₂ "	40	\$ 982

Four 5" plate type casters; two swivel, two swivel with brake.

Capacities listed are the maximum number of 18" x 26" pans each unit will hold. Box capacity is determined by the depth of the box, as well as the guide spacing. Deeper boxes may block the guides, reducing the capacity of the rack.

Options: Options may not be NSF Certified. Contact the factory.

"B", "E", "M6", "PB", "PS", "VB" - see page 71 for details.

- **Transport food boxes and 18" x 26" sheet pans with one rack.**
- Utilize vertical storage space by handling multiple poly food boxes and trays with one rack.
- **All welded aluminum construction with 5" plate type casters.**
- Lifetime Guarantee against rust and corrosion.
- NSF Certified.



1482



1484



▶ Steamtable Pan Rack

Model No.	Size W-H-D	Pan Capacity	Runner Spacing	Ship Lbs.	List Price
½-Size Rack w/ Stainless Steel Top — Side Loading					
1501	24¼" x 35" x 27¾"	16	3"	42	\$ 1,131

Four 5" stem type swivel casters .

Options: Options may not be NSF Certified. Contact the factory.

"CL(A)", "E", "MD", "PS", "VB" - see page 71 for details.

Full Size - End Loading Unit					
52199 *	16¼" x 69" x 22¾"	10	5"	31	\$ 1,030
1505	16¼" x 69" x 22¾"	18	3"	42	\$ 908

Four 5" stem type swivel casters.

Options: Options may not be NSF Certified. Contact the factory.

"CL(A)", "E", "MD", "PS", "VB" - see page 71 for details.

Full Size - Side Loading Units					
1507	23¾" x 69¾" x 27"	20	5"	45	\$ 961
1509	23¾" x 69¾" x 27"	36	3"	52	\$ 1,172

Four 5" plate type swivel casters.

*** Not NSF Certified.**

Options: Options may not be NSF Certified. Contact the factory.

"CL(B)", "E", "MD", "PS", "PB", "VB" - see page 71 for details.

- Transports a large number of pans and product.
- Gussets are welded in all corners to prevent "racking".
- **Designed especially for 12" x 20" steamtable/hotel pans.**
- Units with stem type casters have reinforced channel inserts to increase durability.
- Four, one inch welds per angle guide.
- Lifetime Guarantee against rust and corrosion.
- NSF Certified. (Excluding Item 52199)



52199



1509



▶ Transport/Retrieval Rack

Model No.	Size W-H-D	Tray Capacity	Angle Spacing	Ship Lbs.	List Price
Tray Retrieval Rack					
97743	20¾" x 69½" x 30"	*	5"	54	\$ 1,280
* Tray Capacity = (24) 14" x 18" Trays • (12) 18" x 26" Trays					
97744	22½" x 69½" x 30"	**	5"	57	\$ 1,280
** Tray Capacity = (24) 15" x 20" Trays					
97745	20¾" x 69½" x 30"	***	5"	65	\$ 1,645
*** Tray Capacity = (24) 14" x 18" Trapezoid Trays / Round Trays					

Four 5" plate type swivel casters.

Options: Options may not be NSF Certified. Contact the factory.

"B", "CL(B)", "E", "M6", "MD", "PB", "PS", "VB" - see page 71 for details.



97745



97744



Pan Racks



1331Z

51107

► Nesting Pan Rack - "Z" Type

Model No.	Size W-H-D	Pan Capacity	Runner Spacing	Ship Lbs.	List Price
½-Size Nesting "Z" Pan Rack - Not NSF Certified.					
51107*	20½" x 31½" x 26"	8	3"	39	\$ 1,181
Full-Size Nesting "Z" Pan Racks					
1330Z	20¾" x 69¾" x 26"	30	2"	86	\$ 1,570
1331Z	20¾" x 69¾" x 26"	20	3"	68	\$ 1,377
1332Z	20¾" x 69¾" x 26"	15	4"	61	\$ 1,288
1333Z	20¾" x 69¾" x 26"	12	5"	57	\$ 1,201
Roll-In Nesting "Z" Pan Racks - Not NSF Certified.					
99866*	20¾" x 64¾" x 26"	18	3"	65	\$ 1,517
97379*	20¾" x 64¾" x 26"	11	5"	60	\$ 1,333

Four 5" plate type swivel casters.

Designed to accommodate 13" x 18", 14" x 18" and 18" x 26" pans.

* Not NSF Certified.

Options: Options may not be NSF Certified. Contact the factory.

"CL(B)", "MD", "VB" - see page 71 for details.

6 "Z" Racks = 14.9 sq/ft • 6 Standard Racks = 22.4 sq/ft

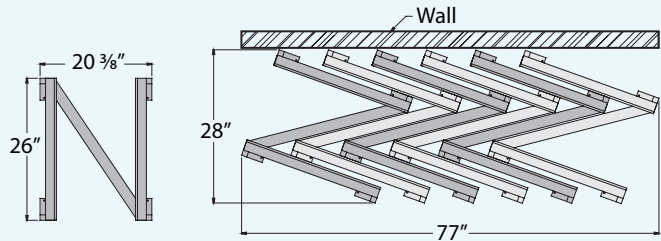

1330U

! All sheet pan racks quoted hold USA standardized 18" x 26" sheet pans (17⅞" x 25⅞" actual). We are not responsible for pans that do not meet the industry standard, which may not fit our racks.

► Nesting Pan Rack - "U" Type

Model No.	Size W-H-D	Pan Capacity	Runner Spacing	Ship Lbs.	List Price
1330U	20¾" x 69¾" x 26"	30	2"	77	\$ 1,506
1331U	20¾" x 69¾" x 26"	20	3"	66	\$ 1,341

Four 5" plate type swivel casters.

Designed to accommodate 13" x 18", 14" x 18" and 18" x 26" pans.

Options: Options may not be NSF Certified. Contact the factory.

"CL(B)", "MD", "PS", "VB" - see page 71 for details.

6 "U" Racks = 13.8 sq/ft • 6 Standard Racks = 22.4 sq/ft

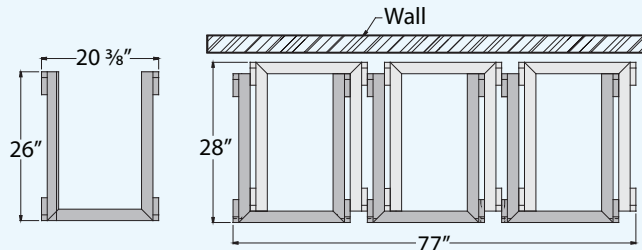

► Universal Stepped-Angle Rack

Model No.	Size W-H-D	Pan Slides	Runner Spacing	Ship Lbs.	List Price
Universal Stepped-Angle Racks					
1640	24½" x 70⅞" x 26"	13 pair	4½"	90	\$ 2,325
1642	24½" x 71⅞" x 26"	20 pair	3"	156	\$ 3,026
Universal Roll-In Stepped-Angle Racks					
1635	24½" x 64½" x 25¼"	12 pair	4½"	82	\$ 2,202
1637	24½" x 64½" x 25¼"	18 pair	3"	109	\$ 2,766

Four 5" plate type swivel casters.

All Welded Unit • Angle Runners Are NOT ADJUSTABLE

Options: Options may not be NSF Certified. Contact the factory.

"CL(B)", "B", "VB", "PS", "PB", "E" - see pg 71 for details.

PAN SIZES:

10" x 20" Roast & Bake Pans • 20" x 22" Roast & Bake Pans • 18" x 26" Roasting Pans •
 18" x 26" Bun Pans • 18" x 13" Bun Pans • 12" x 20" Steam Table Pans • 20¾" x 25½"
 European Std. GastroNorm Pans • 15" x 20" Service Tray • 14" x 18" Service Tray •
 20" x 20" Cup & Glass Racks



1635



1642

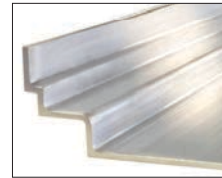

Stepped-Angle Profile



► Wide Angle Rack

Model No.	Size W-H-D	Pan Slides	Runner Spacing	Ship Lbs.	List Price
Wide Angle - Accepts 18" x 26" or 12" x 20" Pans - NSF Certified.					
1305	20¾" x 69¾" x 26"	12 pair	5"	56	\$ 1,321
1306	20¾" x 69¾" x 26"	20 pair	3"	72	\$ 1,755
Extra-Wide Angle - Accepts 18" x 26" or 12" x 20" Pans, and Various Oval Trays.					
96058	26½" x 70⅞" x 30"	10 pair	6"	99	\$ 2,399

Four 5" plate type swivel casters.

Options: Options may not be NSF Certified. Contact the factory.)

"B", "CL(B)", "E", "M6", "MD", "PB", "PP(A)", "PS", "VB" - see page 71 for details.

- Mix-and-match pans to meet your needs.

Wide Angle Racks (1305 & 1306)

- Accommodates 13" x 18", 14" x 18", and 18" x 26" sheet pans, as well as 12" x 20" steamtable pans (by the lip).

Extra-Wide Angle Racks (96058 & 97690)

- Accommodates 13" x 18", 14" x 18", and 18" x 26" sheet pans, 12" x 20" and 20" x 26" steamtable pans, as well as several sizes of oval trays (by the bottom)..

- Welded, reinforced gussets keep the rack square under heavy loads.
- Four, one inch welds per angle guide.
- NSF Certified.



1305



96058



Extra Wide Angle | 96058 & 97690



Pan Racks



1650

► Universal Adjustable Stepped Angle Rack

Model No.	Size W-H-D	Number Of Runners	Minimum Spacing	Ship Lbs.	List Price
Roll-In Unit					
1650	24½" x 64" x 26"	12 pair	1 ½"	82	\$ 2,451
Standard Unit					
1655	24½" x 70" x 26"	13 pair	1 ½"	89	\$ 2,757
Additional Angle Runner					
42068				2	\$ 117

Four 5" plate type swivel casters.
Bottom pan guides are welded in place.

Options: Options may not be NSF Certified. Contact the factory.

"B", "CL(B)", "E", "PB", "PS", "VB" - see page 71 for details.

- Heavy duty utility racks for the transport and storage of product on a large variety of pans. **See page 8 for pan sizes (Universal Stepped Angle Rack).**
- All welded aluminum frame with adjustable universal angles on 1½" centers.
- Roll-in unit fits pass-through refrigerators, freezers, and warming cabinets with inset 5" swivel casters.
- Lifetime Guarantee against rust and corrosion.



► Insert Rack

Model No.	Size W-H-D	Pan Capacity	Angle Spacing	Ship Lbs.	List Price
½-Size Unit - Holds 18" x 26" (Full Size) Sheet Pans					
1610	20¾" x 23" x 24"	7	3"	14	\$ 512
Full Size Unit - Holds 18" x 26" (Full Size) Sheet Pans					
1612	20¾" x 51" x 24"	16	3"	28	\$ 761
97729	20¾" x 51" x 24"	24	2"	35	\$ 814
½-Size Unit - Steamtable - Holds 12" x 20" Steamtable Pans					
97073 *	15⅞" x 23¼" x 22"	7	3"	25	\$ 386

Fits most reach-ins • Requires 21" door clearance.

* Not NSF Certified.

Options: Options may not be NSF Certified. Contact the factory.

"PS" - see page 71 for details.

- All-welded aluminum frame.
- Lifetime Guarantee against rust and corrosion.



1612



1610



Lifetime Series Sheet Pan Racks



Unequalled in construction, Lifetime Series Racks features ergonomically-friendly "D" tube uprights with heavy-duty, ribbed angle guides. Cross-braces are one-inch square tube, secured to vertical uprights and bolstered with a heavy angle gusset at the junction. The all welded base is reinforced at the corners with threaded plates that casters are bolted to, no holes in the framework that compromise the integrity of the rack.

Designed to endure the rigors of around-the-clock usage, these units are ideal for use in the Foodservice, Hospitality, and Healthcare industries, including correctional and educational institutions.

- Ergonomic uprights feature a user-friendly radius that's easy to grip.
- Runners are ribbed, allowing pans to slide on and off with ease, minimizing the galling or flaking that can occur with heavy usage.
- Equipped with four heavy duty, 6" x 2" plate type swivel casters, - Polyurethane tread provides excellent control.
- K-Urethane Caster upgrade available, with or without brakes.
- NSF Certified.



All LIFETIME SERIES products carry a LIFETIME Guarantee against rust and corrosion as well as a LIFETIME Guarantee against material defects and workmanship.



★ Sheet Pan Rack

Model No.	Size W-H-D	Pan Capacity	Angle Spacing	Ship Lbs.	List Price
4330	21½" x 73" x 26"	30	2"	86	\$ 2,931
4331	21½" x 73" x 26"	20	3"	83	\$ 2,484
4332	21½" x 73" x 26"	15	4"	75	\$ 2,332
4333	21½" x 73" x 26"	12	5"	66	\$ 2,211

Four 6" x 2" plate type swivel casters.

Designed to accommodate 13" x 18", 14" x 18" and 18" x 26" pans.

Options: Options may not be NSF Certified. Contact the factory.

"B", "CL(C)" - Standard Casters, "E", "PB", "PP(A)", "PS" - see page 71 for details.

Caster Upgrade — Add "KU" suffix to model #\$ 615
(Four 6" plate type K-Urethane swivel casters.)

Optional Caster Locks for Upgrade - "CL(D)" — see page 71 for details.



- Heavy Duty, 6" x 2" plate type, swivel casters allow for maximum mobility.



- Ergonomic uprights feature a comfortable radius that is easy on user's hands.

! All sheet pan racks quoted hold USA standardized 18" x 26" sheet pans (17⅞" x 25⅞" actual). We are not responsible for pans that do not meet the industry standard, which may not fit our racks.



Lifetime Series Wide-Angle Racks



4340

Accommodate a **WIDE** variety of pan sizes and styles with **ONE** rack. Mix-and-Match pan types to meet your needs! Our lifetime series racks can handle heavy loads with ease.

Designed for institutional, correctional, casino, hotel, university and hospital use — Ideal for facilities that require a durable rack to meet the needs of their around-the-clock usage.

- Ergonomically friendly radius uprights with reinforcing cross bars.
- Heavy Duty, 6" x 2" plate type casters allow for maximum mobility.
- NSF Certified.



All LIFETIME SERIES products carry a LIFETIME Guarantee against rust and corrosion as well as a LIFETIME Guarantee against material defects and workmanship.



★ Wide-Angle Pan Rack | Stepped-Angle Pan Rack



Wide-Angle Pan Racks

#4339 - 20 sets of angle runners
#4340 - 12 sets of angle runners



Stepped-Angle Pan Racks

#4640- 13 sets of angle runners
#4642- 20 sets of angle runners

Model No.	Size W-H-D	Angle Spacing	Ship Lbs.	List Price
Wide-Angle Pan Racks				
4339	21½" x 73" x 26"	3"	99	\$ 3,137
<i>Pan Capacity = (20) 18" x 26", (19) 12" x 20", (40) 13" x 18", (40) 14" x 18"</i>				
4340	21½" x 73" x 26"	5"	81	\$ 2,479
<i>Pan Capacity = (12) 18" x 26", (11) 12" x 20", (24) 13" x 18", (24) 14" x 18"</i>				
Stepped-Angle Pan Racks				
4640	25" x 73" x 26"	4 ½"	142	\$ 3,387
4642	25" x 73" x 26"	3"	158	\$ 4,282

Four 6" x 2" plate type swivel casters.

Accepts: Roast & Bake Pans 20" x 22", 18" x 26" & 10" x 20", Steamtable Pans 12" x 18" & 12" x 20", Bun Pans 18" x 13" & 18" x 26", Service Trays 15" x 20" & 14" x 18", Maxi Pan 20¾" x 25½", Standard GastroNorm Pans 20¾" x 25½"

Note: Angle Runners Are NOT ADJUSTABLE.

Options: Options may not be NSF Certified. Contact the factory.

"B", "CL(C)" standard, "CL(D)" upgrade, "E", "PB", "PP(A)", "PS" - see page 71.

Caster Upgrade - Add "KU" suffix to model #.\$ 615
(Four 6" plate type K-Urethane swivel casters.)

Lifetime Series Roll-In Racks



Roll-In Racks feature the same superior Lifetime Series construction, shortened to fit roll-in freezers, proofers, refrigerators, and retarders.

Designed for institutional, correctional, casino, hotel, university and hospital use — Ideal for facilities that require a durable rack to meet the needs of their around-the-clock usage.

- Casters are inset, swiveling within the perimeter of the rack.
- Two full welds on every angle connection — The most in the industry.
- NSF Certified.



4635



All LIFETIME SERIES products carry a LIFETIME Guarantee against rust and corrosion as well as a LIFETIME Guarantee against material defects and workmanship.



★ Wide-Angle Roll-In Rack | Stepped-Angle Roll-In Rack

Model No.	Size W-H-D	Angle Spacing	Ship Lbs.	List Price
Wide-Angle Roll-In Racks				
4337 **	21½" x 64" x 26"	5"	74	\$ 2,306
<i>Pan Capacity = (11) 18" x 26", (10) 12" x 20", (22) 13" x 18", (22) 14" x 18"</i>				
4338	21½" x 64" x 26"	3"	80	\$ 2,753
<i>Pan Capacity = (18) 18" x 26", (17) 12" x 20", (36) 13" x 18", (36) 14" x 18"</i>				
Stepped-Angle Roll-In Racks				
4635	25" x 64" x 26"	4 ½"	84	\$ 2,895
4637	25" x 64" x 26"	3"	118	\$ 3,652

Four 5" plate type swivel casters.

** Top angle clearance is 4¼".

Accepts: Roast & Bake Pans 20" x 22", 18" x 26" & 10" x 20", Steamtable Pans 12" x 18" & 12" x 20", Bun Pans 18" x 13" & 18" x 26", Service Trays 15" x 20" & 14" x 18", Maxi Pan 20¾" x 25½", Standard GastroNorm Pans 20¾" x 25½"

Note: Angle Runners Are NOT ADJUSTABLE

Options: Options may not be NSF Certified. Contact the factory.

"B", "CL(B)", "E", "PB", "PP(A)", "PS" - see page 71 for details.



Wide-Angle Roll-In Racks

#4337 - 11 sets of angle runners
#4338 - 18 sets of angle runners



Stepped-Angle Roll-In Racks

#4635 - 12 sets of angle runners
#4637 - 18 sets of angle runners



Lifetime Series Transport Cabinet



Our Lifetime Series Transport Cabinet is the toughest in the industry!

Unequaled in construction, this unit is designed to keep product safe and endure around-the-clock usage, including (relentless) truck loading and off-loading. Ideal for use in the foodservice, hospitality, and healthcare industries, including correctional facilities and educational institutions.

- Solid side panels are composed of interlocking aluminum extrusions with guides spaced on 1½" centers for maximum capacity.
- Air circulates top to bottom via a chimney effect created by the formed back panel and panel insert, welded to the reinforced door framework.
- Internal tie rods and a tubular skeleton provide additional strength and durability.
- Tubular supports and inset plates are welded to the solid sheet base; the plates are threaded for bolting casters onto the cabinet, no holes in the framework or base!
- Call the factory to substitute for a (clear) polycarbonate door panel.
- Stainless steel hinges allow the door to open 270 degrees and the flip-down latch clinches the door closed. Available door latch holds the door open and out of the way for efficient loading.
- NSF Certified.

1290WDW

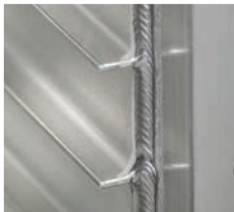

Interlocking aluminum extrusions with guides spaced on 1½" centers



Reinforced center supports.



Door Latch



All LIFETIME SERIES products carry a LIFETIME Guarantee against rust and corrosion as well as a LIFETIME Guarantee against material defects and workmanship.

★ Transport Cabinet

Model No.	Size W-H-D	Pan Cap.	H.D. Base	Ship Lbs.	List Price
Full Size Enclosed Pan Rack — 1½" Runner Spacing					
1290WDW	20¾" x 69" x 27¾"	38	Yes	168	\$4,440

Four 6" x 2" K-Urethane plate type swivel casters.

Equipped with heavy reinforced door.

Units hold 13" x 18", 14" x 18", and 18" x 26" pans by the lip.

Options: Options may not be NSF Certified. Contact the factory.

"B", "CL(D)", "DL", "PB" - see page 71 for details.

Clear Polycarbonate Door - Add "CD" suffix to model #.....Call Factory



All sheet pan racks quoted hold USA standardized 18" x 26" sheet pans (17¾" x 25¾" actual). We are not responsible for pans that do not meet the industry standard, which may not fit our racks.

► Enclosed Transport Cabinet - Heavy Duty

Sheet Pan / Bun Pan Enclosed Cabinets

Model No.	Size W-H-D	Casters	Pan Capacity	H.D. Base	Ship Lbs.	List Price
½-Size Enclosed Pan Rack — 1½" Runner Spacing						
1296	20⅞" x 38" x 27⅝"	5"	20	No	103	\$ 2,614
¾-Size Enclosed Pan Rack — 1½" Runner Spacing						
1293	20⅞" x 56" x 27⅝"	5"	32	Yes	132	\$ 3,051
Full Size Enclosed Pan Rack — 1½" Runner Spacing						
1290	20⅞" x 68" x 27⅝"	5"	40	Yes	159	\$ 3,455
1292*	20⅞" x 69" x 27⅝"	6"	38	Yes	158	\$ 3,905
Solid Sides, Open Ends, Solid Top & Bottom — 1½" Spacing						
1291	20⅞" x 68" x 27⅝"	5"	40	Yes	86	\$ 2,574
Solid Sides, Open Ends - Top & Bottom — 1½" Runner Spacing						
96328	20 ⅝" x 69⅜" x 26½"	5"	39	N/A	82	\$ 2,218

Casters:

5" x 1⅜" polyurethane plate type swivel caster.

6" x 2" polyurethane plate type swivel caster.

* Equipped With A Reinforced Door — Standard

Units hold 13" x 18", 14" x 18", and 18" x 26" pans by the lip.



1290



1290CD

Shown with optional Clear Polycarbonate Door

Steamtable Pan Enclosed Cabinet

Model No.	Size W-H-D	Casters	Pan Capacity	H.D. Base	Ship Lbs.	List Price
Steamtable Pan Enclosed Cabinet — 1½" Runner Spacing						
95141	23¾" x 69" x 27⅜"	5"	24	Yes	166	\$ 4,593

Unit holds 12" x 20" steamtable pans (4" deep). **Not NSF Certified.**

Options: Options may not be NSF Certified. Contact the factory.

"B", "MD" (excluding #1292), "PB", "CL(B)", "CL(C)" - See page 71 for details.

Clear Polycarbonate Door - Add "CD" suffix to model #.....Call Factory

Open Door Latch - Add "DL" suffix to model #.....\$ 31

Reinforced Door - Add "RD" suffix to model #.....\$ 110

Note: #1292 comes equipped with a reinforced door - standard.

Prison Package - Add "PP(B)" suffix to model # (#1290, #1293, & #1296 only).....\$ 442

(4) Welded Hinges

(+) Extra Interior Bracing

(4) 6" Casters

(+) Tamper-Proof Screws & Bolts

(2) Padlock Holes In Door

*** 38 Pan Capacity ***



► Enclosed Transport Cabinet - Standard

Model No.	Size W-H-D	Pan Capacity	Runner Spacing	Ship Lbs.	List Price
1290A	20⅞" x 68" x 27⅝"	40	1 ½"	134	\$3,315

Four 5" plate type swivel casters.

Units hold 13" x 18", 14" x 18", and 18" x 26" pans by the lip.

Options: Options may not be NSF Certified. Contact the factory.

"B", "CL(B)", "PB" - See page 71 for details.

Clear Polycarbonate Door - Add "CD" suffix to model #.....Call Factory

Open Door Latch - Add "DL" suffix to model #.....\$ 31

Reinforced Door - Add "RD" suffix to model #.....\$ 110



1290A



! All sheet pan racks quoted hold USA standardized 18" x 26" sheet pans (17⅞" x 25⅞" actual). We are not responsible for pans that do not meet the industry standard, which may not fit our racks.

Enclosed Cabinets



97243CDCLPB



▶ Angle-Ledge Transport Cabinet

Model No.	Size W-H-D	Runner Spacing	H.D. Base	Reinforced Door	Tie Rod	Ship Lbs.	List Price
97243	21" x 69½" x 29½"	5"	Yes	Yes	1	156	\$ 4,844
<i>Pan Capacity: (12) 18" x 26" • (24) 14" x 18" • (24) 13" x 18"</i>							
97718	21" x 69½" x 29½"	3"	Yes	Yes	2	162	\$ 5,274
<i>Pan Capacity: (20) 18" x 26" • (40) 14" x 18" • (40) 13" x 18"</i>							

Four 5" plate type swivel casters.

Also Available With Other Angle Spacing Options, Call Factory For Quote.

Options: Options may not be NSF Certified. Contact the factory.

"B", "CL(B)", "M6", "MD", "PB" - See page 71 for details.

Open Door Latch - Add "DL" suffix to model #. \$ 31

Clear Polycarbonate Door - Add "CD" suffix to model #. Call Factory



All sheet pan racks quoted hold USA standardized 18" x 26" sheet pans (17⅞" x 25⅞" actual). We are not responsible for pans that do not meet the industry standard, which may not fit our racks.



97746



▶ Universal Adjustable Angle Cabinet

Model No.	Size W-H-D	Angle Spacing	Angle Runners	H.D. Base	Ship Lbs.	List Price
97746	27⅝" x 61½" x 30⅞"	Adj.	11 pair	Yes	255	\$ 6,966
97747	27⅝" x 70½" x 30⅞"	Adj.	13 pair	Yes	243	\$ 7,428
Additional Angle Runner						
42078					2.25	\$ 117

Four 5" plate type swivel caster.

Angle Runners are adjustable on 1½" centers.

Standard equipped with Reinforced Door.

Pan Sizes: 10" x 20" Roast and Bake Pans • 20" x 22" Roast & Bake Pans • 18" x 26" Roasting Pans
18" x 26" Bun Pans • 18" x 13" Pans • 12" x 20" Steam Table Pans • 20 ¾" x 25 ½" European Standard
GastroNorm Pans • 15" x 20" Service Tray • 14" x 18" Service Tray • 20" x 20" Cup & Glass Racks.

Options: Options may not be NSF Certified. Contact the factory.

"B", "CL(B)", "M6", "MD", "PB" - See page 71 for details.

Open Door Latch - Add "DL" suffix to model #. \$ 31

Clear Polycarbonate Door - Add "CD" suffix to model #. Call Factory



All sheet pan racks quoted hold USA standardized 18" x 26" sheet pans (17⅞" x 25⅞" actual). We are not responsible for pans that do not meet the industry standard, which may not fit our racks.

► Enclosed Display Cabinet

Model No.	Size W-H-D	Angle Spacing	Angle Runners	Ship Lbs.	List Price
98063	20 $\frac{7}{8}$ " x 68 $\frac{1}{4}$ " x 27 $\frac{5}{8}$ "	5"	10 pair	162	\$ 4,979

Four 5" plate type swivel casters.

Accommodates 18" x 26" & 13" x 18" pans and trays.

Options: Options may not be NSF Certified. Contact the factory.
 "B", "CL(B)", "PB" — see page 71 for details.

- Provides an attractive display with high product visibility.
- Combines an "open" look with the protection of an enclosed cabinet.
- Lifetime Guarantee against rust and corrosion.



Vented Lexan Side Panels



Angle Guides With Stops



98063



! All sheet pan racks quoted hold USA standardized 18" x 26" sheet pans (17 $\frac{7}{8}$ " x 25 $\frac{7}{8}$ " actual). We are not responsible for pans that do not meet the industry standard, which may not fit our racks.

► Slant Display Rack

Model No.	Size W-H-D	Pan Capacity	Runner Spacing	Ship Lbs.	List Price
1137	28 $\frac{1}{2}$ " x 70" x 22"	7	8 $\frac{3}{4}$ "	32	\$ 852
1139	28 $\frac{1}{2}$ " x 77 $\frac{1}{4}$ " x 22"	9	7 $\frac{1}{2}$ "	38	\$1,007

Four 5" stem type swivel casters.

Designed to accommodate 18" x 26" pans and trays.

Options: Options may not be NSF Certified. Contact the factory.
 "CL(A)", "VB" - see page 71 for details.

- Provides an attractive display with high product visibility.
- All welded aluminum construction.
- Lifetime Guarantee against rust and corrosion.
- NSF Certified.



1139



! All sheet pan racks quoted hold USA standardized 18" x 26" sheet pans (17 $\frac{7}{8}$ " x 25 $\frac{7}{8}$ " actual). We are not responsible for pans that do not meet the industry standard, which may not fit our racks.

Room Service Carts



Room Service Delivery Cart

Model No.	Size W-H-D	Runner Spacing	Pan Capacity	Ship Lbs.	List Price
96005	36¾" x 42¾" x 23"	5"	12	80	\$ 2,700

Four 6" plate type casters; two swivel with brake, two rigid.

Accommodates 15" x 20" trays.

Options:

0350 Vinyl Staph-Check® Cover for #96005 - Not NSF Certified..... \$ 681
-green vinyl cover with velcro closure

- All-welded, aluminum construction is lightweight yet durable.
- Holds 15" x 20" trays with space on the bottom for bus trays.
- Optional cover helps protect contents.
- Equipped with vertical corner bumpers at the top, a full perimeter bumper at the bottom and a vertical pan stop.
- 6" plate type casters provide maneuverability.

96005 shown with optional cover (#0350)



Removable Tray Top



Room Service Tray Return Cart

Model No.	Size W-H-D	Runner Spacing	Pan Capacity	Ship Lbs.	List Price
96004	23" x 59¼" x 31¼"	5"	20	51	\$ 1,098

Four 5" stem type swivel casters.

Accommodates 15" x 20" trays.

Options: Options may not be NSF Certified. Contact the factory.

"CL(A)", "E", "MD" - Casters Locks are unavailable with the MD Option
see page 71 for details.

0351 Vinyl Staph-Check® Cover for #96004 - Not NSF Certified..... \$ 661
- green vinyl cover with velcro closure

- All-welded, aluminum construction is lightweight yet durable.
- Holds 15" x 20" trays.
- Optional "staph check" vinyl cover helps protect contents.
- Equipped with vertical corner bumpers at the bottom as well as a vertical pan stop.

96004 shown with optional cover (#0351)



▶ Donut Display Rack

Model No.	Size W-H-D	Angle Spacing	Pan Capacity	Ship Lbs.	List Price
52711	20 7/8" x 47" x 26 1/2"	8 1/2"	4	110	\$ 6,436

Four 4" plate type casters; two swivel, two swivel with brake.

Accommodates 18" x 26" sheet pans.

Custom made for a national donut chain, this unit was designed to fit into a millwork cabinet. Unit is powder coated and has LED lights.

- LED Light Bars are discreetly mounted under each shelf.
 - Light wiring runs down back side of tube with leg uprights.
- Power supply is mounted inside the base.
- Removable stainless steel tray sits inside base for easy cleaning.
- Can be customized to meet your needs.
- Lifetime Guarantee against rust and corrosion.



LED Light Bars mounted under each shelf



52711



▶ Donut Screen Rack

Model No.	Size W-H-D	Screen Capacity	Screen Size	Ship Lbs.	List Price
NS621KD	26 3/4" x 69" x 26"	20	23" x 23"	52	\$ 939
NS947KD	27 3/4" x 69" x 26"	20	24" x 24"	54	\$ 939
93020KD	26 3/4" x 69" x 33"	20	23" x 33"	62	\$ 1,385

Four 5" stem type swivel casters.

All models are shipped knocked down.

Options: Options may not be NSF Certified. Contact the factory.

"CL(A)", "VB" - see page 71 for details.

- Four, one inch welds per angle guide.
- Standard 3" runner spacing.
- Shipped "Knocked Down" for freight savings.
- Lifetime Guarantee against rust and corrosion.
- NSF Certified.



93020KD



Specialty Racks



1215

► Mobile Fry Cart

Model No.	Size W-H-D	Basket Capacity	Ship Lbs.	List Price
1210	18" x 52½" x 27"	18	29	\$ 870
1215	24½" x 52½" x 27"	27	34	\$ 935

Four 3" plate type swivel casters.

Corner bumpers and removable drip pan are standard.

- Designed to hold fry baskets in or out of the freezer.
- Available in double or triple basket widths.
- All welded aluminum construction.
- Lifetime Guarantee against rust and corrosion.
- NSF Certified.



PM2448 • PM2460

► Pot & Pan Rack

Model No.	Size D-H-L	Number Of Tiers	Ship Lbs.	List Price
Stationary Units				
P2448	24" x 76" x 48"	4	59	\$ 1,338
P2460	24" x 76" x 60"	4	86	\$ 1,612
Mobile Units - 5" stem type swivel casters with brake				
PM2448	24" x 74" x 48"	4	68	\$ 1,646
PM2460	24" x 74" x 60"	4	97	\$ 1,921

All units shipped knocked down.



▶ Oven Rack

New Age Industrial manufactures Oven Racks for the following brands of Rotating Rack Ovens:

- Adamatic
- Gemini
- Revent
- Customer Racks Available, call factory for details.
- Baxter
- Lucks
- Baker's Aid
- Hobart

**Call New Age at 800-255-0104
for catalog information and pricing.**

- The toughest Oven Racks on the market.
- Our quality exceeds any other stainless steel or aluminum rack made.
- **Racks accommodate 18" x 26" sheet pans.**
- Heavy duty, 4" diameter "Hi-Temp" wheel casters.
- Six, 3/4" welds per angle runner...The most in the industry.
- Heavy duty all welded aluminum construction.
- Lifetime Guarantee against rust and corrosion.



1801A



▶ Carrier Cart

Model No.	Size W-H-L	Shelf Size	Number Of Shelves	Shelf Spacing	Ship Lbs.	List Price
95667	20 1/2" x 55" x 64"	20" x 60"	3	top = 17 1/2" bottom = 18 1/2"	175	\$3,541

Four 6" x 2" plate type casters; two swivel, two swivel with brake.

- Multipurpose cart for the storage and transport of food modules, boxes, pots & pans, wire baskets, and similar items.
- Heavy duty all welded construction.
- All three solid shelves have three edges turned up (sides & back), with the front edge turned down.
- Upper two shelves are slanted 1° toward the rear to facilitate drainage.
 - All shelves have drainage holes.
- Equipped with four heavy duty 6" x 2" plate type swivel casters, two with brakes.
- **Shelf clearance = 17 1/2" • Weight Capacity = 1800 lbs.**
- Lifetime Guarantee against rust and corrosion.



95667



Stands



99738



► Mixer Stand

Model No.	Size W-H-D	Ship Lbs.	List Price
99738	29" x 70" x 23"	63	\$ 2,638

Four 5" plate type swivel casters with brake.

Options: Options may not be NSF Certified. Contact the factory.

Cord Wrap - Add "CW" suffix to model #.....\$ 50

- Stainless steel top and undershelf.
- Removable aluminum accessory pole.



99217



► Slicer Stand

Model No.	Size W-H-D	Runner Spacing	Pan Capacity	Ship Lbs.	List Price
99217	28 ³ / ₈ " x 30" x 20"	3"	6	67	\$ 2,162

Four 5" plate type swivel casters with total locks

Options: Options may not be NSF Certified. Contact the factory.

"B", "E", "MD", "PB", "PS" - See page 71 for details.

Cord Wrap - Add "CW" suffix to model #.....\$ 50

- Designed to hold equipment, transport trays, and with the retractable shelf, hold pans while slicing.
- Accommodates 18" x 26" sheet pans.
- Four, one inch welds per angle guide.



Retractable 16 GA Stainless Steel Pull-Out Shelf & Top Bracing

► Slicer/Mixer Stand

Model No.	Size W-H-D	Runner Spacing	Pan Capacity	Ship Lbs.	List Price
98000	23 ¹ / ₄ " x 31 ¹ / ₄ " x 26"	1 ¹ / ₂ "	12	44	\$ 1,708
98001	23 ¹ / ₄ " x 37" x 26"	1 ¹ / ₂ "	16	61	\$ 1,796
98179	23 ¹ / ₄ " x 37" x 26"	3"	8	59	\$ 1,834

Four 5" plate type swivel casters with brake.

Vertical Corner Bumpers (4) are standard.

Designed to accommodate 13" x 18", 14" x 18" and 18" x 26" pans.

Note: Models #98000 & #98001 hold pans by the lip.

Options: Options may not be NSF Certified. Contact the factory.

"B", "E", "MD", "PB", "PS" - See page 71 for details.

Cord Wrap - Add "CW" suffix to model #.....\$ 50



98000



Outrigger Channels

Pizza Pan Racks

► Universal Pizza Pan Rack

Model No.	Size W-H-D	Pan Size	Pan Clearance	Pan Capacity	Ship Lbs.	List Price
Single-Wide • Single-Deep - Ships Knocked Down						
97720	18½" x 72" x 16¾"	12" to 16"	2¾"	20	37	\$ 1,426
97722	20¾" x 72" x 16¾"	10" to 18"	2¾"	20	47	\$ 2,059
99309	20¾" x 72" x 16¾"	14" to 18"	2¾"	20	37	\$ 1,273
99456	Vinyl Cover For Above Units • White with two zippers				6	\$ 367
Single-Wide • Double-Deep - Ships Knocked Down						
97721	18½" x 72" x 32"	12" to 16"	2¾"	40	60	\$ 2,524
99310	20¾" x 72" x 32"	14" to 18"	2¾"	40	62	\$ 2,755
99457	Vinyl Cover For Above Units • White with four zippers				6	\$ 414

Four 5" stem type swivel casters.

Options: Options may not be NSF Certified. Contact the factory.

"CL(A)", "VB" -See page 71 for details.

TABLE TOP UNIT

99970	12" x 24½" x 13"	10" to 18"	1 ¾"	8	9	\$ 800
-------	------------------	------------	------	---	---	--------

- Unique pan guide design accommodates various pan sizes.
- Optional vinyl covers for full-size units have a viewing window.



99970



97720



► Pizza Pan Rack

Model No.	Size W-H-D	Pan Capacity	Description	Runner Spacing	Ship Lbs.	List Price
NS590A	Adj. x 34¾" x 13¾"	13	1 Wide / 1 High	2"	28	\$ 869
NS599A	Adj. x 62½" x 13¾"	26	1 Wide / 2 High	2"	44	\$ 1,264
NS603A	Adj. x 62½" x 13¾"	52	2 Wide / 2 High	2"	70	\$ 2,657
NS596A	Adj. x 62½" x 13¾"	78	3 Wide / 2 High	2"	104	\$ 3,372
NS600A	Adj. x 34¾" x 13¾"	26	2 Wide / 1 High	2"	44	\$ 1,454

Four 5" stem type swivel casters.

Adjustable widths in 1" increments to hold 10" through and including 16" pans.

Width inside uprights = 10½" Minimum • 16½" Maximum

- Each rack is adjustable to accommodate a 10" to 16" pizza pan.
- Units ship knocked down for freight savings.



NS596A



NS599A



► Wall Mount Pan Racks

Model No.	Size W-H-D	Runner Spacing	Pan Capacity	Ship Lbs.	List Price
Holds 13" x 18" (½-Size) Sheet Pans					
50875	20¾" x 21" x 13"	3"	6	14	\$ 861
Holds 18" x 26" (Full Size) Sheet Pans					
98138	28¾" x 21" x 18"	3"	6	21	\$ 996

- Contact the factory for additional sizes and spacing.
- Lifetime Guarantee against rust and corrosion, superior strength and durability guaranteed.

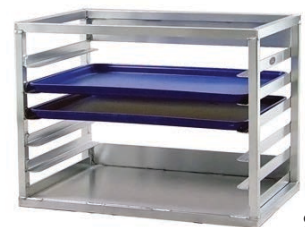

98138



Tray Drying Racks



96704



► Correctional Duty Tray Drying Rack

Model No	Size ** W-H-L	Tray Levels	Guide Clearance	Tray Capacity	Ship Lbs.	List Price
96704	28½" x 64" x 58¼"	3	2.65"	120*	245	\$ 6,333
96705	28½" x 82" x 58¼"	4	2.65"	160*	239	\$ 6,801
96706	28½" x 64" x 69¼"	3	2.65"	144*	282	\$ 6,454
96707	28½" x 82" x 69¼"	4	2.65"	192*	343	\$ 7,431
96708	28½" x 64" x 63½"	3	1.4"	240*	290	\$ 6,332
96709	28½" x 82" x 63½"	4	1.4"	320*	318	\$ 6,801
96710	28½" x 64" x 75½"	3	1.4"	288*	318	\$ 6,454
96711	28½" x 82" x 75½"	4	1.4"	384*	395	\$ 8,187

Four 6" x 2" heavy duty plate type swivel casters with **tamper proof fasteners**.

* Note: Tray Capacity is based on two, compartmented or insulated trays per slot.

** Height varies, based on tray size, confirm with factory when ordering. Above height is based on a 16" tray.

Options: Options may not be NSF Certified. Contact the factory.

"CL(C)", "PB", "VB" - see page 71 for details.

Note: The bottom drainage channel is removed when perimeter and corner bumpers are used.

! These Tray Drying Racks are built-to-order and cannot be returned.

► Tray Drying Racks - Adjustable



95413



Model No	Size W-H-L	Tray Levels	Guide Clearance	Ship Lbs.	List Price
95413	28" x 50½" x 63¾"	2	1.4"	172	\$ 3,636
96090	28" x 50½" x 59"	2	2.65"	159	\$ 3,636
95333	28" x 74½" x 63¾"	3	1.4"	234	\$ 4,979
96087	28" x 74½" x 59"	3	2.65"	219	\$ 4,979

Four 5" plate type swivel casters.

All units shipped knocked down.

Options: Options may not be NSF Certified. Contact the factory.

"CL(B)" - see page 71 for details.

- Shipped "Knocked Down" for freight savings.
- Tray capacity depends on style and size of tray.
 - Model #95413 & #95333 will hold (40) 18" x 26" trays per level (shelf), and #96090 & #96087 will hold (20) 18" x 26" trays per level (shelf).
- Heavy duty tray guides are .090" thick and are ideally spaced on 1½" and 2¾" centers.
 - Actual clearance: 1½" spacing = 1.4" • 2¾" spacing = 2.65"
- Heavy duty aluminum construction.
- Lifetime Guarantee against rust and corrosion.

► Extreme Duty Utility Cart

Model No	Size W-H-L	Shelf Size	Shelf Spacing	Ship Lbs.	List Price
97177	22" x 41" x 37"	21¾" x 33⅝"	27"	66	\$ 2,166
97178	22" x 41" x 54"	21¾" x 50⅝"	27"	82	\$ 2,748
97179	29" x 41" x 37"	28¾" x 33⅝"	27"	72	\$ 2,273
97180	29" x 41" x 54"	28¾" x 50⅝"	27"	142	\$ 2,899

Four 6" plate type casters; two swivel, two rigid.

Options: Options may not be NSF Certified. Contact the factory.

"B", "CL(C)", "PB", "PP(A)", "VB" — see page 71 for details.

- Two-Tier units ideal for use in coolers, freezers, and dry storage.
- Transport heavy loads up to 1500 lbs. per shelf
- 2000 lbs. Rolling Capacity -
- Heavy Duty 6" platform type casters.
- All welded, heavy duty aluminum construction.
- Lifetime Guarantee against rust and corrosion.



97180



► Correctional Duty Utility Cart

Model No	Size W-H-L	Shelf Size	Shelf Spacing	Weight Capacity	Ship Lbs.	List Price
97769	18½" x 39" x 32½"	18½" x 28¾"	14½"	550 lbs.	42	\$1,370

Four 5" plate type casters; two swivel, two rigid. Attached with tamper proof fasteners.

Three tier solid shelf unit: each shelf with three sides up 1 ¼" and one side down 1 ¼".

Options: Options may not be NSF Certified. Contact the factory.

"B", "CL(B)", "VB" — see page 71 for details.

- Ideal three shelf unit for various tasks such as serving, bussing and general utility.
- Strength and durability of stainless steel at much less the cost.
- Lifetime Guarantee against rust and corrosion.



97769



Queen Marys



1455



▶ Queen Mary - Aluminum

Model No.	Size D-H-L	Weight Capacity	Number Of Shelves	Shelf Spacing	Ship Lbs.	List Price
1450	29" x 66 3/4" x 62"	3000 lbs.	5	12"	186	\$ 3,988
1451	29" x 66 3/4" x 75"	2500 lbs.	5	12"	210	\$ 4,463
1452	29" x 66 3/4" x 62"	2500 lbs.	4	16 1/2"	174	\$ 3,642
1455	29" x 66 3/4" x 62"	3000 lbs.	6	9 1/4"	205	\$ 4,441

Four 8" plate type casters; two swivel, two rigid.

Each Unit Is Equipped With A Full Perimeter Bumper.

Options: Options may not be NSF Certified. Contact the factory.

"CL(E)" - see page 71 for details.

Towing Options Available - Call For Pricing

- Built for transporting BIG loads for banquets, catering, and bussing.
- Smooth radius handle and uprights.
- Solid shelves with marine edges add strength and contain spills.
- Standard perimeter bumper protects surfaces.
- Durable, all welded aluminum construction with 8" x 2" casters (standard).
- Model #1451 accepts 23" wide oval trays — 3 wide per shelf.
- Lifetime Guarantee against rust and corrosion.

▶ Queen Mary - Stainless

Model No.	Size D-H-L	Weight Capacity	Number Of Shelves	Shelf Spacing	Ship Lbs.	List Price
97942	29" x 66 3/4" x 65 1/2"	3000 lbs.	5	10 1/2"	355	\$ 8,348
98181	29" x 66 3/4" x 78 1/2"	2500 lbs.	5	10 1/2"	351	\$ 9,567
98182	29" x 66 3/4" x 65 1/2"	2500 lbs.	4	14 1/2"	322	\$ 7,189
98183	29" x 66 3/4" x 65 1/2"	3000 lbs.	6	8 1/4"	365	\$ 9,978

Four 8" plate type casters; two swivel, two rigid.

Each Unit Is Equipped With A Full Perimeter Bumper.

Options:

"CL(E)" - see page 71 for details.

Towing Options Available - Call For Pricing

- Built for transporting BIG loads for banquets, catering, and bussing.
- Durable, all welded aluminum frame with removable stainless steel shelf covers.
- Smooth radius handle and uprights.
- Standard perimeter bumper protects surfaces.
- Equipped with 8" x 2" casters (standard).
- Model #98181 accepts 23" wide oval trays — 3 wide per shelf.
- Lifetime Guarantee against rust and corrosion.



98182



Scrap and Stack

Model Number	Size W-H-D	Ship Lbs.	List Price
53757	40" x 35" x 27¾"	65	\$ 2,273

Equipped with four, 5" plate type swivel casters, total lock brakes.

Option: - Factory Installed Only

Handle - Add "H" Suffix to model #.\$ 98
Unit with handle measures 38" H.

Built-in storage for empty steamtable and sheet pans makes this the go-to cart for quick and easy serving line cleanup.

- 12" x 12" waste chute with removable, easy to clean waste receptacle.
- **Top mounted pan rail holds two rows of stacked 12" x 20" steamtable pans.**
- **Angle slides mounted below holds stacked 18" x 26" sheet pans.**
- Removable receptacle for soiled spatulas, spoodles, and other serving utensils.
- 5" plate type swivel casters with total locks, provide easy maneuverability and stability.
- Lifetime Guarantee against rust and corrosion.



53757



53757H



Share Cart

Model No.	Size D-H-L	Ship Lbs.	List Price
52861*	23 ¼" x 70" x 29 7/16"	100	\$ 6,446

* Must select color option.

Four 5" plate type casters, two swivel, two swivel with brake. All welded aluminum construction.

Note: Poly food boxes, custom signs and any other accessories are not included and must be purchased by end user.

Option: - Factory Installed Only - Must select color option

- **52918 - Cold Pan Shelf**\$ 1,124
Hinged, drop-down shelf built to hold ½-size cold pan.
- **52919 - Computer/Tablet Shelf**\$ 889
Hinged, drop down shelf for a computer/tablet.

Color Options:

- **Red** - Add "RED" suffix to model #.
- **Orange** - Add "ORANGE" suffix to model #.
- **Yellow** - Add "YELLOW" suffix to model #.
- **Green** - Add "GREEN" suffix to model #.
- **Blue** - Add "BLUE" suffix to model #.
- **Purple** - Add "PURPLE" suffix to model #.
- **Black** - Add "BLACK" suffix to model #.

Initially designed for schools as a "Share Cart", this versatile cart can be seen in nursing homes, stadiums and club stores.

- Two locations for custom signs.
- Top shelf designed to hold two Coldmaster CoolCheck™ drop-ins. (pans included)
- Smooth radius push handle.
- Slanted second shelf for easy access and storage.
- Reinforced base shelf for miscellaneous storage.
- Lifetime Guarantee against rust and corrosion.



52861PURPLE



No Ice Required!

Comes with two, Coldmaster CoolCheck™ drop-ins.



52918BLUE



52919ORANGE



Dollies



1171



NS926



1630



Removable Drip Tray

Chill Dolly

Model No.	Size W-L	Description	Ship Lbs.	List Price
1171	22 1/2" x 21 1/2"	Single Stack	18	\$ 548
1172	22 1/2" x 42 1/2"	Double Stack	21	\$ 604
1174		Handle	8	\$ 110

Four 5" plate type casters; two swivel, two rigid.

Accepts Nestier®, Buckhorn® chillpac containers 20" x 24".

NS968	19" x 8" x 22 3/8"	Single Stack	16	\$ 451
-------	--------------------	--------------	----	--------

Four 5" plate type swivel casters.

Accepts Nestier®, Buckhorn® chillpac containers 20" x 24".

Options: Options may not be NSF Certified. Contact the factory.

"CL(B)" - see page 71 for details.

- Heavy duty transport dollies...Ideal for cook-chill systems.
- Weight Capacity = 1000 lbs.
- Open base provides maximum air circulation.
- Lifetime Guarantee against rust and corrosion.
- NSF Certified.

Crisping Basket Dolly

Model No.	Size W-H-L	Ship Lbs.	List Price
NS926	26 3/4" x 8" x 29 3/4"	18	\$ 457
Crisping Baskets - Sold Separately - Not NSF Certified.			
0307	26" x 9" x 29"	8	\$ 207

Aluminum Drag Hook- Not NSF Certified.

1199	37 1/2" Long	1	\$ 40
------	--------------	---	-------

Four 5" plate type casters; two swivel, two rigid.

#NS926 Does Not Include A Crisping Basket

Options: Options may not be NSF Certified. Contact the factory.

"CL(B)" - see page 71 for details.

- Superior strength and versatility for maximum loads
- Lifetime Guarantee against rust and corrosion.
- NSF Certified.

Food Box Dolly

Model No.	Size W-H-L	Weight Capacity	Deck Height	Ship Lbs.	List Price
1630	24" x 36" x 33"	500 lbs.	12"	27	\$1,238
1631	24" x 36" x 33"	500 lbs.	16"	29	\$1,238
Aluminum Drag Hook- Not NSF Certified.					
1199	37 1/2" Long			1	\$ 40

Four 5" stem type swivel casters.

Removable Drip Tray Included.

Options: Options may not be NSF Certified. Contact the factory.

"CL(A)" - see page 71 for details.

- Superior strength and versatility for maximum loads.
- Lifetime Guarantee against rust and corrosion.
- NSF Certified.

► Mobile Dish Rack

Model No.	Size W-H-D	Tray Capacity	Runner Spacing	Ship Lbs.	List Price
Standard Units					
NS345	22" x 65" x 20 1/2"	8	7"	30	\$ 817
93037	22" x 69" x 20 1/2"	6	10"	30	\$ 735

Four 5" stem type swivel casters.

Options: Options may not be NSF Certified. Contact the factory.

"CL(A)", "PS", "VB" - see page 69 for details.

Model No.	Size W-H-D	Tray Capacity	Runner Spacing	Ship Lbs.	List Price
Roll-In Unit					
97142	22" x 64" x 20 1/2"	9	6"	45	\$ 987

Four 5" plate type swivel casters.

Options: Options may not be NSF Certified. Contact the factory.

"B", "CL(B)", "MD", "PB", "PS", "VB" - see page 71 for details.

All units accept 20" x 20" dish racks.

- These mobile racks easily move heavy loads.
- Eliminate wasted storage space.
- Lifetime Guarantee against rust and corrosion.
- NSF Certified.



NS345



97142



► Wall Mount Dish Rack Holder

Model No.	Size W-H-D	Tray Capacity	Runner Spacing	Ship Lbs.	List Price
53082	29" x 22 1/2" x 18"	6	4 1/2"	21	\$ 958
52924	61 1/2" x 22 1/2" x 18"	13	4 1/2"	38	\$ 1,496

Wall mount hardware is not included.

All units accept 20" x 20" dish racks.

- Designed to hold dish racks for storage and drying.
- Keeps racks easily accessible above sinks, tables and bussing stations.
- Eliminate wasted storage space.
- Can be customized to meet your requirements.
- Lifetime Guarantee against rust and corrosion.



52924



► Dish Rack Dolly

Model No.	Number of Stacks	Size W-H-D	Weight Capacity	Ship Lbs.	List Price
1176A	Single	20 5/8" x 9 3/8" x 22 3/8"	1000 lbs.	23	\$ 693
1179A	Handle			5.5	\$ 85

Four 5" plate type swivel casters.

All units accept 20" x 20" dish racks.

Options: Options may not be NSF Certified. Contact the factory.

"B", "CL(B)" - see page 71 for details.

- One piece solid pan construction with 1 1/2" lips up on all sides to contain spills.
- Optional handle available.
- Heavy duty aluminum construction with four 5" plate type casters.
- Lifetime Guarantee against rust and corrosion.
- NSF Certified.



1176A



1179A



Dollies

► Bowl Dolly



95636



98716
Accommodates Vollrath 80QT
mixing bowl, model #79800.



Model No.	Size W-H-D	Ring Diameter	Quart Size	Ship Lbs.	List Price
Mixer Bowl Dolly/Stand - NSF Certified.					
95636	26 ³ / ₄ " x 30 ³ / ₈ " x 26 ³ / ₄ "	20 ¹ / ₄ " I.D.	80	34	\$ 826
98736	24 ³ / ₄ " x 30 ³ / ₈ " x 24 ³ / ₄ "	18 ¹ / ₄ " I.D.	60	28	\$1,203
98737	29 ³ / ₈ " x 30 ³ / ₈ " x 29 ³ / ₈ "	22 ⁷ / ₈ " I.D.	140	29	\$1,211

Four 5" plate type casters; two swivel, two swivel w/ brake.

Note: Unit Heights Do Not Include Bowls

Information is based on Hobart® mixing bowl sizes.

Options: "B" - see page 71 for details. (Options may not be NSF Certified. Contact the factory.)

Mixing Bowl Dolly - Not NSF Certified.

98716	30" x 30" x 30"	29 ¹ / ₂ " I.D.	80	24	\$1,122
-------	-----------------	---------------------------------------	----	----	---------

Four 5" plate type swivel casters.

Accommodates Vollrath 80QT mixing bowl, model #79800.

Options: "B" - see page 71 for details. Options may not be NSF Certified. Contact the factory.

► Mixer Bowl Transport Dolly



99936



Model No.	Size W-H-D	Weight Capacity	Ship Lbs.	List Price
99936	14" x 7 ⁹ / ₁₆ " x 14"	800 lbs.	15	\$ 644

Four 3" plate type swivel casters.

Designed to hold an 40-120 quart bowl.

- Designed to make rolling heavy mixing bowls in and out of place an easy task, this rust proof unit is ideal for the kitchen/prep room atmosphere.

► Mixing Bowl/Pan Rack Dolly



51949



Model No.	Size W-H-D	Ring Diameter	Quart Size	Runner Spacing	Pan Capacity	Ship Lbs.	List Price
Mixing Bowl Dolly - Not NSF Certified.							
51949	22" x 31 ⁵ / ₈ " x 26"	20.875" I.D.	30	4"	4	35	\$ 1,861

Four 5" plate type swivel casters with total lock.

Accommodates 30QT. mixing bowl and 18" x 26" sheet pans, not included.

- This Mixing Bowl Dolly is designed to hold a 30 quart mixing bowl, as well as full size standard sheet pans, at a working height; Minimizing uncomfortable working positions.
- Equipped with four 5" plate type swivel casters.
- Five-Year Guarantee against material defects and workmanship.
- Lifetime Guarantee against rust and corrosion.

Pan Dollies

Model No.	Size W-H-D	Weight Capacity	Ship Lbs.	List Price
Angle Dolly Without Sides or Handle				
1192	18 ⁷ / ₈ " x 7" x 27"	800 lbs.	18	\$ 404
Angle Dolly With Sides & Handle				
1193	21" x 33 ¹ / ₂ " x 28 ¹ / ₂ "	900 lbs.	25	\$ 699
Two Tier Angle Dolly With Sides & Handle				
1194	21" x 44 ¹ / ₂ " x 30"	900 lbs.	33	\$ 908

Four 5" plate type swivel casters.

Accommodates 18" x 26" sheet pans.

Options: Options may not be NSF Certified. Contact the factory.

"CL(B)", "MD", "PP(A)" - see page 71 for details.



1193 • 1194 • 1192



97055

Oval Tray Dolly - Not NSF Certified.

97055	26 ³ / ₈ " x 33 ³ / ₄ " x 30"	800 lbs.	36	\$ 1,220
-------	---	----------	----	----------

Four 5" plate type casters; two swivel, two swivel with brake.

Accommodates up to 23¹/₂" x 29" oval trays.

Options: Options may not be NSF Certified. Contact the factory.

"CL(B)" - see page 71 for details.

Steamtable Pan Dolly - Not NSF Certified.

4-Bay

98998	30" x 48" x 44"	1000 lbs.	69	\$ 2,216
-------	-----------------	-----------	----	----------

2-Bay

98195	30" x 64" x 22"	1000 lbs.	46	\$ 1,497
-------	-----------------	-----------	----	----------

Four 5" plate type swivel casters.

Accommodates up to 12" x 20" steam table pans.

Options: Options may not be NSF Certified. Contact the factory.

"CL(B)" - see page 71 for details.



98195



98998



Aluminum Drag Hook- Not NSF Certified.

1199	37 ¹ / ₂ " Long		1	\$ 40
------	---------------------------------------	--	---	-------

Bulk Sheet Pan Dolly

Model No.	Size W-H-D	Pan Capacity	Ship Lbs.	List Price
50112	27 ³ / ₄ " x 73" x 28 ¹ / ₂ "	140	68	\$ 1,868

Four 8" plate type swivel casters.

Accommodates 18" x 26" sheet pans.

- Ideal for hotel, casino, hospital and correctional facilities.
- This unit will store and transport up to 140 sheet pans.
 - Designed to hold sheet pans at a backward angle to keep the stack from tipping forward outside of the frame.
- Can be customized to meet your specific needs.
- Lifetime Guarantee against rust and corrosion.



50112



Bread Pan Dolly

Model No.	Size W-H-D	Weight Capacity	Ship Lbs.	List Price
Angle Dolly - Holds 5 strap 1lb. loaf pans (9²/₃₂" x 26")				
93189	21 ⁷ / ₈ " x 6" x 28 ¹ / ₈ "	800 lbs.	17	\$ 450

Four 3" plate type swivel casters.

Universal Bread Pan Dolly

95219	26 ³ / ₄ " x 9" x 30 ³ / ₈ "	800 lbs.	24	\$ 554
-------	--	----------	----	--------

Four 5" plate type swivel casters.

Options: Options may not be NSF Certified. Contact the factory.

"CL(B)" - see page 71 for details. ***Model #95219 Only***

Aluminum Drag Hook- Not NSF Certified.

1199	37 ¹ / ₂ " Long		1	\$ 40
------	---------------------------------------	--	---	-------



93189



Dollies



1622 NSF



1620

► Milk Crate Dolly

Model No.	Size W-H-D	Number Of Stacks	Crate Capacity	Ship Lbs.	List Price
1620	13¾" x 9" x 28¼"	2	8	19	\$ 425
1622	26¾" x 9" x 28¼"	4	16	22	\$ 483

Four 5" swivel type plate casters.

Options: Options may not be NSF Certified. Contact the factory.

"CL(B)" - see page 71 for details.

Aluminum Drag Hook - Not NSF Certified.					
1199	37½" Long			1	\$ 40

- Accommodates 13" x 13" Milk Crates.
- Superior strength and versatility for maximum loads.
- Lifetime Guarantee against rust and corrosion.



1182 NSF



1199



► Super Dolly

Model No.	Size W-H-D	Wheel Size	Weight Capacity	Ship Lbs.	List Price
1181	24" x 10" x 29½"	6"	2800 lbs.	30	\$ 715
1182	24" x 8" x 29½"	5"	1000 lbs.	18	\$ 551

Four plate type casters:

#1181= two swivel, two rigid

#1182= two swivel, two rigid

Options: Options may not be NSF Certified. Contact the factory.

"B", "CL(C)" (Model #1181), "CL(B)" (Model #1182) - see page 71.

Aluminum Drag Hook - Not NSF Certified.					
1199	37½" Long			1	\$ 40

► Chicken Dolly

Model No.	Size W-H-D	Weight Capacity	Ship Lbs.	List Price
1187	24" x 14" x 30¼"	500 lbs.	24	\$ 770

Replacement Drip Pan - Not NSF Certified.

1188			5	\$ 201
------	--	--	---	--------

Aluminum Drag Hook - Not NSF Certified.

1199	37½" Long		1	\$ 40
------	-----------	--	---	-------

Four 5" stem type casters; two swivel, two with brake.

Comes equipped with drip pan.

- Specifically designed to stack iced or frozen foods.
- Compact dollies keep drips, spills and condensation to a minimum with a sturdy, removable drip pan.
- Lifetime Guarantee against rust and corrosion.
- NSF Certified.



1187



► Dough Dolly

Model No.	Size W-H-D	Wheel Size	Ship Lbs.	List Price
-----------	------------	------------	-----------	------------

Dough Dollies - Accepts 25³/₄" x 2⁵/₁₆" x 17¹³/₁₆" trays or boxes.

1195	18" x 5 ¹ / ₂ " x 25 ¹ / ₂ "	3"	12	\$ 316
1196	18" x 8" x 25 ¹ / ₂ "	5"	14	\$ 404

Accepts Cambro® #DB18263CW & Toteline® trays Model #870008.
Toteline is a registered trademark of Molded Fiber Glass Tray Co.

Pizza Dough Box Dolly- Accepts 18" x 26" dough boxes.

98040	20 1/2" x 7 1/4" x 27 1/4"	5"	18	\$ 522
-------	----------------------------	----	----	--------

Aluminum Drag Hook- for Model #98040 Not NSF Certified.

1199	37 1/2" Long		1	\$ 40
------	--------------	--	---	-------

Casters:

#1195 = Four 3" plate type swivel casters.

#1196 & #98040 = Four 5" plate type swivel casters.

Options: Options may not be NSF Certified. Contact the factory.

"CL(B)" - see page 69 for details.



1195 • 1196



98040



► Utility/Bussing Cart

Utility Bussing Cart

Model No.	Size W-H-D	Shelf Size	Shelf Spacing	Weight Capacity	Ship Lbs.	List Price
-----------	------------	------------	---------------	-----------------	-----------	------------

3-Tier

NS745	18 1/2" x 39" x 32 1/2"	18 1/2" x 28 3/4"	13"	350 lbs.	35	\$ 981
1440	16 1/2" x 39" x 27 3/4"	16 1/2" x 24"	13"	350 lbs.	29	\$1,003

Four 5" stem type casters; two swivel, two swivel with brake.

Each shelf with three sides up 1/4" and one side down 1/4".

Options: Options may not be NSF Certified. Contact the factory.

"B", "MD", "VB" - see page 71 for details.

Lug Dolly / Bussing Cart

Model No.	Size W-H-D	Weight Capacity	Ship Lbs.	List Price
-----------	------------	-----------------	-----------	------------

99304	17 1/4" x 41 1/2" x 28"	150 lbs.	21	\$ 779
-------	-------------------------	----------	----	--------

Four 5" stem type swivel casters.

Not NSF Certified.



NS745 NSF

99304



► Bus Tub Wall Shelf

Model No.	Size W-H-D	Number Of Tiers	Shelf Clearance	Ship Lbs.	List Price
-----------	------------	-----------------	-----------------	-----------	------------

98272	24" x 30" x 16"	2	12"	22	\$ 733
-------	-----------------	---	-----	----	--------

98301	36" x 30" x 16"	2	12"	24	\$ 904
-------	-----------------	---	-----	----	--------

98213	48" x 30" x 16"	2	12"	35	\$1,090
-------	-----------------	---	-----	----	---------

98142	60" x 30" x 16"	2	12"	45	\$1,157
-------	-----------------	---	-----	----	---------



98272



Weight Capacity = Determined by installation method and type of wall

Can Racks



1227



1235

▶ 1/2-Size Can Rack

Model No.	Size W-H-D	Can Cap.		Top Style	Ship Lbs.	List Price
		#10	#5			
1/2-Size - Can Rack (41" Tall)						
1225	25" x 41" x 35"	72	96	Stainless	73	\$ 1,780
1226	25" x 41" x 35"	72	96	Aluminum	60	\$ 1,428
1226NT	25" x 41" x 35"	72	96	None	50	\$ 1,309
1227	25" x 41" x 35"	72	96	Poly	72	\$ 1,545
Counter Height - Can Rack (35" Tall)						
1235	25" x 35" x 35"	54	72	Stainless	68	\$ 1,659
1236	25" x 35" x 35"	54	72	Aluminum	57	\$ 1,311
1236NT	25" x 35" x 35"	54	72	None	44	\$ 1,194
1237	25" x 35" x 35"	54	72	Poly	69	\$ 1,424

Template for mounting Edlund No.1 Can Opener included.
Four 5" plate type casters; two swivel with brake and two rigid.

Options: Options may not be NSF Certified. Contact the factory.

"PP(A)" - see page 71 for details.

1255 Solid Shelf Trays (3)\$ 117

- Each unit boasts heavy gauge aluminum construction with the most welds in the industry, insuring years of strength and durability.
- Easily loaded/unloaded with one hand providing automatic stock rotation when loaded from the rear.
- Lifetime Guarantee against rust and corrosion.
- NSF Certified.



1250CK



▶ Full Size Can Rack - Heavy Duty

Model No.	Size W-H-D	Can Capacity				Casters	Ship Lbs.	List Price
		#10	#5	#2½	#303			
1250*	25" x 71" x 35"	162	216	**	**	No	100	\$ 1,632
1250CK	25 ½" x 78" x 35"	162	216	**	**	Yes	125	\$ 2,042
1251*	23" x 66" x 35"	**	**	352	484	No	112	\$ 2,536
1254*	25" x 73" x 35"	**	288	**	**	No	102	\$ 2,271
1256*	25 ½" x 71" x 47"	216	297	**	**	No	130	\$ 2,330
1256CK	26" x 77 ¼" x 47"	216	297	**	**	Yes	137	\$ 2,791

* Units without casters are equipped with adjustable feet.

***** Casters Can Not Be Retrofitted - Factory option only. *****

"CK" Units: Equipped with four 6" plate type casters; two swivel with brake, two rigid.

Options: Options may not be NSF Certified. Contact the factory.

"PP(A)" - see page 71 for details

1255Solid Shelf Trays (3) - fits 35" deep Can Racks\$ 117

1257Solid Shelf Trays (3) - fits 47" deep Can Racks - **Not NSF Certified.**\$ 193

Adjustable Feet Replacement Available

- Superior quality.
- Adjustable feet are standard with stationary units.
- Lifetime Guarantee against rust and corrosion.
- NSF Certified.

► F.I.F.O. Can Rack - Heavy Duty

Model No.	Size W-H-D	Can Capacity #10	Ship Lbs.	List Price
Stationary Unit				
97294	27 1/8" x 79 1/2" x 42"	156	190	\$ 5,820
Adjustable Feet Standard.				
Mobile Unit				
97294CK	27 1/8" x 81 1/8" x 42"	156	208	\$ 6,304

Four 6" plate type casters; two swivel with brake, two rigid.

Options: Options may not be NSF Certified. Contact the factory.

Adjustable Feet Replacement Available

- Automatically rotates stock — Loaded and retrieved from the front!
- Easily loaded from the front, no need to move it out from the wall.
- Holds (156) #10 cans within 8 square feet.



First Can In...
First Can Out.



97294

► F.I.F.O. Can Rack - Standard

Model No.	Size W-H-D	Can Capacity #10	Ship Lbs.	List Price
Stationary Unit				
99381	26 5/8" x 78 1/4" x 42"	156	140	\$ 4,217

Adjustable Feet Standard.

Options: Options may not be NSF Certified. Contact the factory.

Adjustable Feet Replacement Available

****Casters Can Not Be Placed On This Unit****

- Automatically rotates stock — Loaded and retrieved from the front!
- Easily loaded from the front, no need to move it out from the wall.
- Holds (156) #10 cans within 8 square feet.



First Can In...
First Can Out.



99381

► Full Size Can Rack - Standard

Model No.	Size W-H-D	Can Capacity		Casters	Ship Lbs.	List Price
		#10	#5			
6259	25" x 71" x 35 1/4"	162	216	No	86	\$1,257

Adjustable Feet Standard.

****Casters Can Not Be Placed On This Unit****

- Adjustable feet standard equipment.
- Store up to (162) #10 cans or (216) #5 cans in only six square feet of space.
- Provides automatic stock rotation when loaded from the rear.
- Inclined angle glides give you easy access to a large number of cans with one unit.



6259

Dunnage Racks

► Mobile Dunnage Rack



1203

1203 with 1208 optional handle



Model No.	Size D-H-L	Weight Capacity	Ship Lbs.	List Price
1201	20" x 8¼" x 25¾"	1000 lbs.	21	\$ 616
1211	20" x 8¼" x 31¾"	1000 lbs.	21	\$ 628
1202	20" x 8¼" x 37¾"	1000 lbs.	22	\$ 648
1200	20" x 8¼" x 43¾"	1000 lbs.	25	\$ 665
1203	20" x 8¼" x 49¾"	1000 lbs.	27	\$ 686
1212	20" x 8¼" x 61¾"	1000 lbs.	24	\$ 721
1208	Handle for 20" W Units Above		6	\$ 110
1213	24" x 8¼" x 25¾"	1000 lbs.	20	\$ 618
1214	24" x 8¼" x 31¾"	1000 lbs.	22	\$ 636
1204	24" x 8¼" x 37¾"	1000 lbs.	24	\$ 655
1205	24" x 8¼" x 43¾"	1000 lbs.	27	\$ 674
1206	24" x 8¼" x 49¾"	1000 lbs.	27	\$ 691
1207	24" x 8¼" x 61¾"	1000 lbs.	30	\$ 725
1174	Handle for 24" W Units Above		7.5	\$ 110

Four 5" plate type casters; two swivel with brake, two rigid.

Options: Options may not be NSF Certified. Contact the factory.

Heavy Duty Casters -Add "HD6" suffix to model #. \$ 140

Four 6" plate type casters; two swivel with brake, two rigid.

All Swivel Casters -Add "SW" suffix to model #. \$ 34

► Dunnage Rack Covers



Model No.	Size D-L	Ship Lbs.	List Price
Anti-Slip Covers			
51101	20" x 36"	11	\$ 350
51102	20" x 48"	14.5	\$ 459
51103	20" x 60"	18	\$ 521
Solid Cover			
95456	20" x 36"	4.5	\$ 201

Fits 2000 and 6000 Series Dunnage Racks with same D x L dimensions.

Does NOT fit Lifetime Series Racks.

Dunnage Rack sold separately.

- Anti-Slip, Raised tread, perforated top, has 3" O.C. Spacing - Disrupted elevation = 3/16".
- Removable sheet nests over Dunnage Rack frame.
- All Aluminum, Guaranteed Rust Free!

► Dunnage Rack - Standard



6000 Series - Dunnage Racks



Model No.	Size D-H-L	Weight Capacity	Number Of Laterals	Ship Lbs.	List Price
6017	20" x 8" x 36"	2000 lbs.	4	8	\$216
6018	20" x 8" x 48"	2000 lbs.	4	10	\$232
6019	20" x 8" x 60"	1500 lbs.	4	13	\$256
6004	20" x 12" x 36"	2000 lbs.	4	9	\$216
6005	20" x 12" x 48"	2000 lbs.	4	11	\$232
6006	20" x 12" x 60"	1500 lbs.	4	14	\$256
6014	24" x 8" x 36"	2000 lbs.	5	9	\$231
6015	24" x 8" x 48"	2000 lbs.	5	11	\$261
6016	24" x 8" x 60"	1500 lbs.	5	14	\$298
6008	24" x 12" x 36"	2000 lbs.	5	10	\$231
6009	24" x 12" x 48"	2000 lbs.	5	12	\$261
6010	24" x 12" x 60"	1500 lbs.	5	15	\$298

► Dunnage Rack - Heavy Duty

Model No.	Size D-H-L	Weight Capacity	Number Of Laterals	Ship Lbs.	List Price
2001	18" x 8" x 36"	3000 lbs.	4	9	\$254
2002	18" x 8" x 48"	2500 lbs.	4	11	\$296
2003	18" x 8" x 60"	2000 lbs.	4	13	\$338
2029	18" x 12" x 24"	3200 lbs.	4	7	\$221
2020	18" x 12" x 36"	3000 lbs.	4	10	\$268
2021	18" x 12" x 48"	2500 lbs.	4	14	\$311
2022	18" x 12" x 60"	2000 lbs.	4	17	\$353
2017	20" x 8" x 36"	3000 lbs.	4	9	\$268
2018	20" x 8" x 48"	2500 lbs.	4	12	\$311
2019	20" x 8" x 60"	2000 lbs.	4	13	\$353
2051	20" x 12" x 24"	3000 lbs.	4	8	\$308
2052	20" x 12" x 30"	3000 lbs.	4	10	\$261
2004	20" x 12" x 36"	3000 lbs.	4	11	\$268
2054	20" x 12" x 42"	3000 lbs.	4	13	\$307
2005	20" x 12" x 48"	2500 lbs.	4	15	\$311
2006	20" x 12" x 60"	2000 lbs.	4	18	\$353
2031	24" x 8" x 24"	3000 lbs.	5	9	\$288
2014	24" x 8" x 36"	2500 lbs.	5	11	\$322
2015	24" x 8" x 48"	2500 lbs.	5	14	\$375
2016	24" x 8" x 60"	2000 lbs.	5	17	\$426
2032*	24" x 8" x 72"	4000 lbs.	5	20	\$612
2013	24" x 12" x 24"	2500 lbs.	5	9	\$288
2062	24" x 12" x 30"	2500 lbs.	5	11	\$308
2008	24" x 12" x 36"	2500 lbs.	5	15	\$322
2064	24" x 12" x 42"	2500 lbs.	5	15	\$365
2009	24" x 12" x 48"	2500 lbs.	5	21	\$375
2033	24" x 12" x 54"	2000 lbs.	5	17	\$499
2010	24" x 12" x 60"	2000 lbs.	5	24	\$426
2012*	24" x 12" x 72"	4000 lbs.	5	27	\$570
2026	30" x 12" x 36"	3000 lbs.	6	14	\$413
2027	30" x 12" x 48"	3000 lbs.	6	19	\$449
2028	30" x 12" x 60"	2500 lbs.	6	20	\$542
2007*	30" x 12" x 72"	4000 lbs.	6	27	\$742

* Models have 6 legs.

Options: Options may not be NSF Certified. Contact the factory.

Removable Aluminum Cover - Call For Pricing.

Custom Sizes Available - Call For Pricing.

Dunnage Racks



2000 Series - Dunnage Racks

- All feet are permanently sealed with welded aluminum caps... Not plastic.
- All welded aluminum racks keep product organized and off of the floor.
- Lifetime Guarantee against rust and corrosion.
- **E-Channel and Stacking units available** — Call factory for details.
- NSF Certified.



The toughest Dunnage Rack on the market.
These all welded racks are "beefed up" to hold maximum weight capacities up to 5000 pounds.

★ Dunnage Rack

Model No.	Size W-H-D	Weight Capacity	Ship Lbs.	List Price
4004	20" x 12" x 36"	5000 lbs.	18	\$ 609
4005	20" x 12" x 48"	4000 lbs.	21	\$ 679
4006	20" x 12" x 60"	3400 lbs.	23	\$ 747
4008	24" x 12" x 36"	4000 lbs.	21	\$ 715
4009	24" x 12" x 48"	4000 lbs.	25	\$ 794
4010	24" x 12" x 60"	4000 lbs.	27	\$ 872
4027	30" x 12" x 48"	4000 lbs.	31	\$ 959
4065	36" x 12" x 48"	4000 lbs.	35	\$1,126



All LIFETIME SERIES products carry a LIFETIME Guarantee against rust and corrosion as well as a LIFETIME Guarantee against material defects and workmanship.



Shelving



H.D. Series Three Shelf Unit



H.D. Series Three Shelf Unit
w/ Optional "M6" Casters
Casters are factory installed only.

- Ideal for **correctional facilities, supermarkets, hotels, and institutions.**
- Built to organize larger, heavier loads.
- New Age uses the heaviest aluminum extrusion for maximum life and strength.
- Mobile units available — Factory installed only.
- **All non-mobile units include adjustable feet.**
- Lifetime Guarantee against rust and corrosion, **superior** for refrigerated environments.
- E-Channel units available — Call factory for details.



▶ All Welded Shelving - H.D. Series

Model No.	Size D-H-L	Shelf Laterals	Ship Lbs.	List Price
Two Shelf Unit - 34½" Shelf Clearance				
1021	20" x 48" x 36"	4	53	\$ 652
1030	20" x 48" x 42"	4	56	\$ 789
1022	20" x 48" x 48"	4	60	\$ 731
1023	20" x 48" x 60"	4	65	\$ 816
1024	20" x 48" x 72"	4	71	\$ 895
1025	24" x 48" x 36"	5	56	\$ 740
1031	24" x 48" x 42"	5	60	\$ 776
1026	24" x 48" x 48"	5	63	\$ 815
1027	24" x 48" x 60"	5	69	\$ 916
1028	24" x 48" x 72"	5	74	\$ 1,020
Three Shelf Unit - 22½" Shelf Clearance				
1041	20" x 60" x 36"	4	56	\$ 855
1050	20" x 60" x 42"	4	64	\$ 968
1042	20" x 60" x 48"	4	67	\$ 961
1043	20" x 60" x 60"	4	78	\$ 1,077
1044	20" x 60" x 72"	4	87	\$ 1,202
1045	24" x 60" x 36"	5	61	\$ 987
1051	24" x 60" x 42"	5	75	\$ 1,053
1046	24" x 60" x 48"	5	75	\$ 1,129
1047	24" x 60" x 60"	5	82	\$ 1,263
1048	24" x 60" x 72"	5	93	\$ 1,411
Four Shelf Unit - 18½" Shelf Clearance				
1061	20" x 72" x 36"	4	65	\$ 1,045
1070	20" x 72" x 42"	4	80	\$ 1,251
1062	20" x 72" x 48"	4	83	\$ 1,204
1063	20" x 72" x 60"	4	91	\$ 1,364
1064	20" x 72" x 72"	4	111	\$ 1,529
1065	24" x 72" x 36"	5	71	\$ 1,226
1071	24" x 72" x 42"	5	81	\$ 1,343
1066	24" x 72" x 48"	5	85	\$ 1,419
1067	24" x 72" x 60"	5	102	\$ 1,622
1068	24" x 72" x 72"	5	117	\$ 1,808



Mobile Units — *Factory Options Only*

6" Plate type swivel casters

- Add "M6" suffix to model #..... \$ 574

5" Plate type swivel casters

- Add "M5" suffix to model #..... \$ 430

Options: Options may not be NSF Certified. Contact the factory.

"CL(B)", "CL(C)", "PP(A)" - see page 71 for details.



Stationary Units | Weight Capacity = 1500 lbs. per shelf

Contact Factory for Mobile Unit Capacities.

► All Welded Shelving - T-Bar Series

Model No.	Size D-H-L	Ship Lbs.	List Price
Two Shelf Unit - 34¼" Shelf Clearance			
1021TB	20" x 48" x 36"	55	\$ 785
1030TB	20" x 48" x 42"	57	\$ 806
1022TB	20" x 48" x 48"	67	\$ 869
1023TB	20" x 48" x 60"	73	\$ 981
1024TB	20" x 48" x 72"	77	\$ 1,097
1025TB	24" x 48" x 36"	56	\$ 815
1031TB	24" x 48" x 42"	63	\$ 885
1026TB	24" x 48" x 48"	69	\$ 945
1027TB	24" x 48" x 60"	76	\$ 1,068
1028TB	24" x 48" x 72"	80	\$ 1,194
Three Shelf Unit - 22¼" Shelf Clearance			
1041TB	20" x 60" x 36"	62	\$ 1,005
1050TB	20" x 60" x 42"	67	\$ 1,068
1042TB	20" x 60" x 48"	76	\$ 1,163
1043TB	20" x 60" x 60"	91	\$ 1,324
1044TB	20" x 60" x 72"	96	\$ 1,487
1045TB	24" x 60" x 36"	70	\$ 1,111
1051TB	24" x 60" x 42"	76	\$ 1,211
1046TB	24" x 60" x 48"	78	\$ 1,293
1047TB	24" x 60" x 60"	89	\$ 1,495
1048TB	24" x 60" x 72"	103	\$ 1,673
Four Shelf Unit - 18¼" Shelf Clearance			
1061TB	20" x 72" x 36"	78	\$ 1,244
1070TB	20" x 72" x 42"	83	\$ 1,347
1062TB	20" x 72" x 48"	88	\$ 1,462
1063TB	20" x 72" x 60"	103	\$ 1,692
1064TB	20" x 72" x 72"	119	\$ 1,908
1065TB	24" x 72" x 36"	90	\$ 1,400
1071TB	24" x 72" x 42"	92	\$ 1,557
1066TB	24" x 72" x 48"	97	\$ 1,639
1067TB	24" x 72" x 60"	112	\$ 1,902
1068TB	24" x 72" x 72"	127	\$ 2,147



T-Bar Series Three Shelf Unit
w/ Optional "M5" Casters
Casters are factory installed only.



T-Bar Series Four Shelf Unit



Mobile Units — *Factory Options Only*

6" Plate type swivel casters

- Add "M6" suffix to model #..... \$ 574

5" Plate type swivel casters

- Add "M5" suffix to model #..... \$ 430

Options: Options may not be NSF Certified. Contact the factory.

"CL(B)", "CL(C)", "PP(A)" - see page 71 for details.



Closeup: Underside of T-Bar Shelf.

- **Ideal for correctional facilities.**
- Each unit has easy-to-clean flat surfaces that aid in the easy-on and easy-off of smaller product with the strength to hold heavy product.
- These all welded units keep product organized and off of the floor while providing adequate air flow.
- New Age "T's" are 2¼" wide and spaced 1¾" apart, giving our T-Bar shelves the most surface area.
- **All non-mobile units include adjustable feet.**
- Mobile units available — Factory installed only.
- Lifetime Guarantee against rust and corrosion, **superior** for refrigerated environments.



Stationary Units | Weight Capacity = 1000 lbs. per shelf

Contact Factory for Mobile Unit Capacities.

Shelving

▶ Adjust-A-Shelf Shelving | H.D. Series Heavy Duty



Complete Unit Shown With
(3) HD Shelves
(4) Posts (pg 43)



Adjust-A-Shelf — H.D. Series

- With weight capacities at one ton (2000#) per shelf, these units will hold almost anything!
- Built To Organize Large, Heavy Loads.
- Lifetime Guarantee against rust and corrosion, superior for refrigerated environments.
- E-Channel units available — Call factory for details.



EASY Order Complete Units with **ONE** model number.

Visit our Website
NewAgeIndustrial.com
for more information

Model No.	Size D-L	Shelf Laterals	Ship Lbs.	List Price Per Shelf
1530HD	15" x 30"	3	6.2	\$ 196
1536HD	15" x 36"	3	7	\$ 201
1542HD	15" x 42"	3	7.5	\$ 212
1548HD	15" x 48"	3	8.8	\$ 219
1554HD	15" x 54"	3	9.5	\$ 233
1560HD	15" x 60"	3	10.3	\$ 246
1566HD	15" x 66"	3	11.6	\$ 276
1572HD	15" x 72"	3	12	\$ 268
1830HD	18" x 30"	4	7	\$ 213
1836HD	18" x 36"	4	8.7	\$ 221
1842HD	18" x 42"	4	9	\$ 235
1848HD	18" x 48"	4	11.5	\$ 254
1854HD	18" x 54"	4	11.8	\$ 262
1860HD	18" x 60"	4	12.3	\$ 310
1866HD	18" x 66"	4	13.8	\$ 323
1872HD	18" x 72"	4	14.8	\$ 330
2030HD	20" x 30"	4	8.2	\$ 216
2036HD	20" x 36"	4	8.7	\$ 221
2042HD	20" x 42"	4	9.6	\$ 233
2048HD	20" x 48"	4	12.8	\$ 254
2054HD	20" x 54"	4	13.4	\$ 265
2060HD	20" x 60"	4	13.9	\$ 284
2066HD	20" x 66"	4	14.9	\$ 303
2072HD	20" x 72"	4	16.4	\$ 330
2096HD*	20" x 96"	4	19	\$ 458
2430HD	24" x 30"	5	9	\$ 274
2436HD	24" x 36"	5	10	\$ 296
2442HD	24" x 42"	5	11.6	\$ 310
2448HD	24" x 48"	5	13.2	\$ 332
2454HD	24" x 54"	5	15	\$ 349
2460HD	24" x 60"	5	17.3	\$ 371
2466HD	24" x 66"	5	18	\$ 389
2472HD	24" x 72"	5	19.6	\$ 404
2496HD*	24" x 96"	5	24	\$ 502
3030HD	30" x 30"	6	10.5	\$ 331
3036HD	30" x 36"	6	12.4	\$ 353
3048HD	30" x 48"	6	16.2	\$ 402

Constructed of 1½" x 1¾" extruded aluminum tubing.

* 96" Shelves Require 6 Posts.

See Page 43 For Posts & Accessories.

Design Your Own Custom Unit

- All three series of "Adjust-A-Shelf" Shelving (the same length and width) are interchangeable.
- This allows you to custom make your own complete units with the type of shelving (H.D., T-Bar, Solid Brute) you need.
- Each unit assembles in minutes with only an allen wrench.



Weight Capacity = 2000 lbs. per shelf



Complete Unit Shown With
(4) T-Bar Shelves
(4) Posts (pg 43)
(4) 5" Stem Type Casters (pg 43)



Closeup: Underside of T-Bar Shelf.



Adjust-A-Shelf — T-Bar Series

- Unique T-Bar construction allows for easy-on, easy-off of product for easy storage while providing maximum air circulation.
- Wide T-Bar and 1 3/4" space between "T"s gives more welds per "T" and more shelf surface.
- Lifetime Guarantee against rust and corrosion, superior for refrigerated environments.
- NSF Certified.

Design Your Own Custom Unit

- All three series of "Adjust-A-Shelf" Shelving (the same length and width) are interchangeable.
- This allows you to custom make your own complete units with the type of shelving (H.D., T-Bar, Solid Brute) you need.
- Each unit assembles in minutes with only an allen wrench.



Weight Capacity = 1500 lbs. per shelf

EASY Order Complete Units with **ONE** model number.

Visit our Website NewAgeIndustrial.com for more information

Shelving

► Adjust-A-Shelf Shelving | Solid Brute Series Heavy Duty



Complete Unit Shown With
(5) Solid Brute Shelves
(4) Posts (pg 43)



Adjust-A-Shelf - Solid Brute Series

Model No.	Size D-L	Ship Lbs.	List Price Per Shelf
1530SB	15" x 30"	8	\$ 304
1536SB	15" x 36"	9.5	\$ 334
1542SB	15" x 42"	10.5	\$ 347
1548SB	15" x 48"	11.5	\$ 350
1554SB	15" x 54"	13	\$ 418
1560SB	15" x 60"	14	\$ 425
1830SB	18" x 30"	9	\$ 324
1836SB	18" x 36"	10	\$ 291
1842SB	18" x 42"	11.5	\$ 309
1848SB	18" x 48"	12.5	\$ 307
1854SB	18" x 54"	14	\$ 420
1860SB	18" x 60"	15	\$ 383
1872SB	18" x 72"	17.5	\$ 414
2030SB	20" x 30"	9	\$ 382
2036SB	20" x 36"	11	\$ 284
2042SB	20" x 42"	12.3	\$ 343
2048SB	20" x 48"	14	\$ 333
2054SB	20" x 54"	15.4	\$ 378
2060SB	20" x 60"	15.8	\$ 389
2066SB	20" x 66"	17.5	\$ 688
2072SB	20" x 72"	18	\$ 451
2430SB	24" x 30"	10.5	\$ 338
2436SB	24" x 36"	11.8	\$ 315
2442SB	24" x 42"	13.4	\$ 351
2448SB	24" x 48"	16.5	\$ 338
2454SB	24" x 54"	17	\$ 389
2460SB	24" x 60"	18.4	\$ 414
2466SB	24" x 66"	19.2	\$ 578
2472SB	24" x 72"	23.2	\$ 478

This solid shelf with reinforced bars provides a flat, smooth surface.

See Page 43 For Posts & Accessories.

- **Unique removable top permits easy clean-up while the reinforced under-bracing gives added support.**
- Lifetime Guarantee against rust and corrosion, **superior** for refrigerated environments.
- NSF Certified.



EASY Order Complete Units with **ONE** model number.

Visit our Website
NewAgeIndustrial.com
for more information

Design Your Own Custom Unit

- All three series of "Adjust-A-Shelf" Shelving (the same length and width) are interchangeable.
- This allows you to custom make your own complete units with the type of shelving (H.D., T-Bar, Solid Brute) you need.
- Each unit assembles in minutes with only an allen wrench.



Weight Capacity = 800 lbs. per shelf

▶ Adjustable H.D. Shelf - Standard

Model No.	Weight Capacity	Size W-L	Ship Lbs.	List Price Per Shelf
C1836HD	1100 lbs.	18" x 36"	7	\$ 198
C1848HD	1100 lbs.	18" x 48"	7.5	\$ 254
C1860HD	1100 lbs.	18" x 60"	9.2	\$ 272
C2436HD	1100 lbs.	24" x 36"	7.75	\$ 261
C2448HD	1100 lbs.	24" x 48"	10.1	\$ 313
C2460HD	1100 lbs.	24" x 60"	12.5	\$ 331
C2472HD	500 lbs.	24" x 72"	14.7	\$ 342

See Page 43 For Posts & Accessories.

- Built to accommodate heavier product and designed for use in all environments including freezers, coolers, as well as packaging and storage areas.
- Lifetime Guarantee against rust and corrosion.
- NSF Certified.



H.D. Style Shelf



▶ Adjustable T-Bar Shelf - Standard

Model No.	Weight Capacity	Size W-L	Ship Lbs.	List Price Per shelf
C1836TB	900 lbs.	18" x 36"	7.4	\$ 254
C1848TB	900 lbs.	18" x 48"	8	\$ 279
C1860TB	900 lbs.	18" x 60"	10	\$ 304
C2436TB	900 lbs.	24" x 36"	8	\$ 255
C2448TB	900 lbs.	24" x 48"	10.6	\$ 270
C2460TB	900 lbs.	24" x 60"	13	\$ 339
C2472TB	500 lbs.	24" x 72"	16.3	\$ 369

See Page 43 For Posts & Accessories.

- Built to accommodate smaller item and heavier loads for use in all environments including freezers, coolers, as well as packaging and storage areas.
- Lifetime Guarantee against rust and corrosion.
- NSF Certified.



T-Bar Style Shelf



▶ Adjustable Solid Shelf - Standard

Model No.	Weight Capacity	Size D-L	Ship Lbs.	List Price Per Shelf
1530S	400 lbs.	15" x 30"	6.3	\$ 259
1536S	400 lbs.	15" x 36"	6.9	\$ 284
1542S	400 lbs.	15" x 42"	7.6	\$ 303
1548S	400 lbs.	15" x 48"	8.9	\$ 311
1830S	400 lbs.	18" x 30"	7.3	\$ 261
1836S	400 lbs.	18" x 36"	7.3	\$ 235
1842S	400 lbs.	18" x 42"	9.2	\$ 296
1848S	400 lbs.	18" x 48"	11	\$ 270
2030S	400 lbs.	20" x 30"	8.5	\$ 279
2036S	400 lbs.	20" x 36"	8.8	\$ 247
2042S	400 lbs.	20" x 42"	9.8	\$ 295
2048S	400 lbs.	20" x 48"	13	\$ 268

Economical solid shelf with double thick marine edge.

Page 43 For Posts & Accessories.

- Organizes Smaller, Lighter Product. Solid sheet design permits easy clean-up and minimizes the mess of "leaky" products.



Solid Style Shelf



EASY Order Complete Units with **ONE** model number.

Visit our Website NewAgeIndustrial.com for more information



Shelving

► Adjust-A-Shelf Shelving - Accessories



a. Floor Post Bracket



b. Wall Bracket

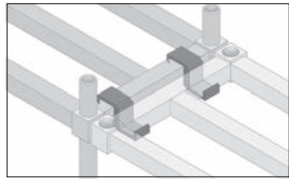

c. Pole Clip



d. U-Brace



e. Casters



f. Adjustable Foot



g. Handle/Desk



h. Handle



j. Document Tray



i. Trash Can

Design Your Own Custom Unit

- All three series of "Adjust-A-Shelf" Shelving (the same length and width) are interchangeable.
- This allows you to custom make your own complete units with the type of shelving (H.D., T-Bar, Solid Brute) you need.
- Each unit assembles in minutes with only an allen wrench.

Model No.	Item Description	Ship Lbs.	List Price
Brackets			
a. NS496	Countertop/Floor Post Brackets	.5	\$ 32
b. NS885	Wall Brackets (pair): Secures Shelving to Wall	1	\$ 47
Attach shelving units to the floor or wall to meet the Seismic Requirements of most states.			
Pole Clips *** H.D. & T-Bar Shelves (pages 39-40) Only ***			
c. PC432	Common Pole Clips (pair)	.25	\$ 29
Clip two units together, shelf to shelf, and eliminate two posts.			
U-Braces			
2036UB	U-Brace for 20" x 36" Shelves	4	\$129
2042UB	U-Brace for 20" x 42" Shelves	4.9	\$132
2048UB	U-Brace for 20" x 48" Shelves	5.5	\$134
2060UB	U-Brace for 20" x 60" Shelves	6.8	\$140
2436UB	U-Brace for 24" x 36" Shelves	5.1	\$148
2442UB	U-Brace for 24" x 42" Shelves	5.8	\$148
2448UB	U-Brace for 24" x 48" Shelves	6.6	\$148
2460UB	U-Brace for 24" x 60" Shelves	7.9	\$148
Adds extra support, keeping posts stable between large spans.			
e. Casters			
C440	5" Stem Type Casters w/ Brakes	2.5	\$ 77
Casters are heavy duty, easily installed and can be added in the field.			
Adjustable Feet			
f. 0116	Adjustable Feet	.5	\$ 30
Adjustable Feet are easily installed and can be added in the field.			
g. Handle/Desk with Tray			
50313	Fits 24"D Shelf Only	14	\$ 715
h. 1½" Tube Handle			
50314	Fits 24"D Shelf Only	3	\$ 169
i. Trash Can with Hanger			
50315	Fits 24"D Shelf Only	13	\$ 431
j. Document Tray			
50316	4"D x 4"H x 16½"L • Fits 24"D Shelf Only	5	\$584

Posts



Model No.	Length	Ship Lbs.	List Price
12P	12"	.6	\$ 26
34P	34"	1.7	\$ 44
48P	48"	2.5	\$ 50
54P	54"	3	\$ 50
60P	60"	3	\$ 69
68P	68"	3.6	\$ 61
72P	72"	3.9	\$ 62
76P	76"	4	\$ 65
84P	84"	4.1	\$ 69

Capped aluminum pipe (1½" o.d.).
Marked in 2" increments.
Weight Capacity = 1500lbs. per post.



Wall Shelves

Model No.	Size D-L	Weight Capacity	Number Of Hooks	Ship Lbs.	List Price
a. T-Bar Wall Shelf / Pot Rack					
1121PR	20" x 36"	700 lbs.	6	15	\$ 444
1122PR	20" x 48"	600 lbs.	7	21	\$ 529
1123PR	20" x 60"	500 lbs.	8	26	\$ 609

Adjustable pot rack hooks slide easily into place to fit your needs.
Additional Pot Hooks Available.

Model No.	Size D-L	Weight Capacity	Ship Lbs.	List Price
b. T-Bar Wall Shelves				
1121	20" x 36"	700 lbs.	11	\$ 333
1122	20" x 48"	600 lbs.	14	\$ 367
1123	20" x 60"	500 lbs.	16	\$ 428
1124	24" x 60"	500 lbs.	26	\$ 568

Heavy duty shelf design for larger, heavier product.

c. Slanted T-Bar Wall Shelves				
97102	21" x 48"	600 lbs.	26	\$ 1,175

d. Solid Wall Shelves- Regular 18 GA				
NS675	12" x 24"	200 lbs.	5	\$ 212
1125	12" x 36"	150 lbs.	7	\$ 207
1126	12" x 48"	125 lbs.	8	\$ 224
1127	12" x 60"	100 lbs.	9	\$ 242

For lighter loads and smaller product, contains spills.

Options: Extra Undershelf Brackets - Call Factory

d. Solid Wall Shelves - Heavy Duty 12 GA				
NS675A	12" x 24"	300 lbs.	6	\$ 236
1125A	12" x 36"	300 lbs.	8	\$ 267
1126A	12" x 48"	225 lbs.	11	\$ 298
1127A	12" x 60"	150 lbs.	13	\$ 347
NS753	15" x 24"	300 lbs.	5	\$ 304
NS943	15" x 36"	300 lbs.	7	\$ 333
NS793	15" x 48"	225 lbs.	11	\$ 389
94249	15" x 60"	150 lbs.	12	\$ 437
95634	18" x 24"	300 lbs.	8	\$ 272
92093	18" x 36"	300 lbs.	10	\$ 378
92094	18" x 48"	225 lbs.	13	\$ 474
94136	18" x 60"	150 lbs.	15	\$ 567

Thick, 12 gauge for heavier loads. Performs like stainless steel.

Options: Extra Undershelf Brackets - Call Factory

e. Microwave Shelf - Heavy Duty 12 GA				
95634	18" x 24"	300 lbs.	8	\$ 272
95883	24" x 24"	300 lbs.	10	\$ 285

f. Inverted Shelves - T-Bar - Not NSF Certified.				
97285	20" x 36"	500 lbs.	11	\$ 341
97286	20" x 48"	500 lbs.	14	\$ 411
97287	20" x 60"	500 lbs.	16	\$ 541

- Lifetime Guarantee against rust and corrosion.
- NSF Certified.



Weight Capacity = Determined by installation method and type of wall



Shelving

▶ “Quick Change” Cantilever Shelving-Free-Standing



The above free-standing unit consists of the following:

- a. H.D. Shelf (2)
- b. T-Bar Shelf (2)
- c. Solid Shelf (2)
- d. Right Upright (1)
- e. Common Upright (1)
- f. Left Upright (1)
- g. Horizontal Brace (2 pair)

Note: One pair required per shelving section.

EASY Order Complete Units with **ONE** model number.

Visit our Website NewAgeIndustrial.com for more information

Ordering Instructions

- Determine the number of shelving sections in the shelving run – Find type, number, and depth of shelves required per section. **a, b, c**
- Add a pair of horizontal braces per shelving section. **g**
- Shelving sections 3', 4', and 5' long require two uprights, one left and one right. **d, f**
- Run lengths over 5' require a left and right upright on the ends and a common upright between each section. (as shown in the picture above). **d, e, f**

Note

- Shelving runs are described in one foot increments. The actual length of a run is an additional 2 3/4", i.e. a typical 7' run is actually 7' 2 3/4" (86 3/4") long.

Model No.	Size D-L	Weight Capacity	Ship Lbs.	List Price
a. H.D. Bar Shelf				
2501	18" x 36"	900 lbs.	6.5	\$ 216
2502	18" x 42"	900 lbs.	8.5	\$ 224
2503	18" x 48"	900 lbs.	9	\$ 239
2505	18" x 60"	900 lbs.	11.2	\$ 260
2511	24" x 36"	900 lbs.	8.3	\$ 261
2512	24" x 42"	900 lbs.	8.7	\$ 271
2513	24" x 48"	900 lbs.	9.2	\$ 288
2515	24" x 60"	900 lbs.	11	\$ 311

Full radius front edge.

b. T-Bar Shelf				
2521	18" x 36"	900 lbs.	9.5	\$ 276
2522	18" x 42"	900 lbs.	10.5	\$ 301
2523	18" x 48"	900 lbs.	11.8	\$ 322
2525	18" x 60"	900 lbs.	14.6	\$ 379
2531	24" x 36"	900 lbs.	11	\$ 308
2532	24" x 42"	900 lbs.	13.5	\$ 334
2533	24" x 48"	900 lbs.	14.5	\$ 353
2535	24" x 60"	900 lbs.	17	\$ 421

Ideal for smaller product as well as heavier loads.

c. Solid Reinforced Shelf				
2541	18" x 36"	700 lbs.	9.5	\$ 381
2542	18" x 42"	700 lbs.	10.5	\$ 470
2543	18" x 48"	700 lbs.	12	\$ 405
2545	18" x 60"	700 lbs.	14.6	\$ 451
2551	24" x 36"	700 lbs.	11	\$ 401
2552	24" x 42"	700 lbs.	12	\$ 483
2553	24" x 48"	700 lbs.	13	\$ 444
2555	24" x 60"	700 lbs.	19	\$ 495

For smaller products and spill control.

Model No.	Item Description	Ship Lbs.	List Price
g. Horizontal Brace — Free-Standing Units Only			
2581	36" Horizontal Brace (2)	3.9	\$ 74
2582	42" Horizontal Brace (2)	4.8	\$ 89
2583	48" Horizontal Brace (2)	5.8	\$ 89
2585	60" Horizontal Brace (2)	6.7	\$ 111
Free-Standing Uprights — 72" in Height			
f. 2561	21" Left Upright • 18" Shelves	12.5	\$ 435
d. 2563	21" Right Upright • 18" Shelves	12.5	\$ 435
e. 2565	21" Common Upright • 18" Shelves	14	\$ 512
f. 2571	27" Left Upright • 24" Shelves	13.5	\$ 450
d. 2573	27" Right Upright • 24" Shelves	13.5	\$ 450
e. 2575	27" Common Upright • 24" Shelves	14.5	\$ 530

Uprights have locking tabs spaced on 12" centers and an extended leg with adjustable foot.

Model No.	Item Description	Ship Lbs.	List Price
Self Divider — Free-Standing & Ceiling Mounted Units			
h. 51233	60" Vertical Divider	14.5	\$ 808

Attaches securely to uprights – Sold Separately

Not NSF Certified.





a.

H.D. Bar Shelf • 900 lbs. Weight Capacity



b.

T-Bar Shelf • 900 lbs. Weight Capacity



c.

Solid Brute Shelf • 700 lbs. Weight Capacity



Ceiling Mounted Unit

Ordering Instructions

- Determine the number of shelving sections in the shelving run – Find type, number, and depth of shelves required per section.
- Horizontal braces are not needed.
- Shelving sections 3', 4', and 5' long require two uprights, one left and one right.
- Run lengths over 5' require a left and right upright on the ends and a common upright between each section. (as shown in the picture above).

Note

- Upright height (length) is determined by ceiling height.
- Actual shelf depth from the wall to the front of the shelf is 3" more than the listed shelf depth.
- The actual shelving run length is found by adding 6½" to the sum of the shelf lengths in a shelving run — a typical 7' shelving run which uses a 36" shelf length and a 48" shelf length is actually 90½" long (7' 6½").



► “Quick Change II” Cantilever Shelving-Ceiling Mounted

Model No.	Item Description	Ship Lbs.	List Price
Ceiling Mounted Uprights - Not NSF Certified.			
95403	72" Left Upright	9	\$ 472
95404	72" Right Upright	9	\$ 472
95405	72" Common Upright	10.5	\$ 509
97753	84" Left Upright	10.5	\$ 485
97755	84" Right Upright	10.5	\$ 485
97754	84" Common Upright	11.4	\$ 529
95631	96" Left Upright	12.5	\$ 490
95632	96" Right Upright	12.5	\$ 490
95633	96" Common Upright	13	\$ 541
96617	108" Left Upright	14.5	\$ 515
96618	108" Right Upright	14.5	\$ 515
96619	108" Common Upright	15	\$ 612

Uprights have locking tabs spaced on 12" centers.

Keg Shelving



NS933



51171



Keg Shelf Close-up



U-Brace / Wall Protectors

▶ Keg Stacker - Single-Deep

Model No.	Size D-H-L	½-Barrel Capacity	¼-Barrel Capacity	Number Of Shelves	Ship Lbs.	List Price
Complete Units						
31842TT7 †	18" x 76" x 42"	4	12	3	49	\$ 991
NS933	18" x 76" x 60"	6	18	3	71	\$ 1,311
NS475 †	18" x 76" x 72"	8	22	3	73	\$ 1,487
1288	18" x 76" x 80"	8	26	3	78	\$ 1,479
1289 *	20¾" x 76" x 93"	10	34	3	98	\$ 1,758
Keg Shelves Only – Posts (see pg 43) **Customize Your Own Units**						
94273	18" x 3" x 60"	3	9	1	14.4	\$ 387
95410 †	18" x 3" x 72"	4	11	1	16.5	\$ 438
94274	18" x 3" x 80"	4	13	1	21	\$ 461
94275 *	20¾" x 3" x 93"	5	17	1	23	\$ 549

A. U-Brace / Wall Protectors - Not NSF Certified.

94029	18" x 2" x 60"				7.5	\$ 160
1872UB †	18" x 2" x 72"				5.4	\$ 158
94030	18" x 2" x 80"				9	\$ 172
94031 **	19¾" x 2" x 93"				10	\$ 188

* Shelves Require Six Posts; This adds 2¾" to the overall depth.

** Requires Six Posts; This adds 1¾" to overall depth

† Not NSF Certified.

▶ Keg Stacker - Double-Deep - Not NSF Certified.

Model No.	Size D-H-L	½-Barrel Cap.	¼-Barrel Cap.	Number Of Shelves	Ship Lbs.	List Price
Complete Units						
51169	34" x 84" x 42"	8	24	3	90	\$ 2,383
51170	34" x 84" x 54"	12	30	3	103.9	\$ 2,583
51171	34" x 84" x 60"	12	36	3	117	\$ 2,621
51172	34" x 84" x 72"	16	42	3	137	\$ 3,034
51173*	36¾" x 84" x 80"	16	48	3	214	\$ 3,418
51174*	36¾" x 84" x 93"	20	54	3	226	\$ 3,925
Keg Shelves Only – Posts (see pg 43) **Customize Your Own Units**						
51019	34" x 3" x 42"	4	12	1	27	\$ 702
51020	34" x 3" x 54"	6	15	1	35	\$ 847
51021	34" x 3" x 60"	6	18	1	42	\$ 852
51022	34" x 3" x 72"	8	21	1	50	\$ 1,017
51023*	36¾" x 3" x 80"	8	24	1	49	\$ 1,102
51024*	36¾" x 3" x 93"	10	27	1	57	\$ 1,259
Top Shelves – Standard T-Bar ** Not For Kegs **						
51025	34" x 2" x 42"	n/a	n/a	1	17	\$ 586
98951	34" x 2" x 54"	n/a	n/a	1	21.5	\$ 615
98953	34" x 2" x 60"	n/a	n/a	1	24	\$ 637
50723	34" x 2" x 72"	n/a	n/a	1	27	\$ 722
51026*	36¾" x 2" x 80"	n/a	n/a	1	31	\$ 798
51027*	36¾" x 2" x 93"	n/a	n/a	1	43	\$ 990
A. U-Brace / Wall Protectors						
51298	34" x 2" x 42"	n/a	n/a	n/a	6	\$ 345
51299	34" x 2" x 54"	n/a	n/a	n/a	7	\$ 365
51181	34" x 2" x 60"	n/a	n/a	n/a	8.5	\$ 381
51300	34" x 2" x 72"	n/a	n/a	n/a	9	\$ 403
51280**	35⅜" x 2" x 80"	n/a	n/a	n/a	10	\$ 475
51182**	35⅜" x 2" x 93"	n/a	n/a	n/a	11	\$ 516

* Requires Six Posts; This adds 2¾" to the overall depth.

** Requires Six Posts; This adds 1¾" to overall depth

Keg Shelving

▶ Keg Stacker Accessories

Model No.	Size W-H-L	Ship Lbs.	List Price	Model No.	Size W-H-L	Ship Lbs.	List Price
a. Solid Shelf Cover — Single-Deep Units Only				Solid Shelf Cover — Double-Deep Units Only			
96492	18" x 2" x 42"	5	\$ 235	51328	34" x 2" x 42"	10	\$ 506
51268	18" x 2" x 54"	6	\$ 365	51270	34" x 2" x 54"	13	\$ 386
95435	18" x 2" x 60"	6	\$ 247	52352	34" x 2" x 60"	15	\$ 444
95549	18" x 2" x 72"	7	\$ 277	51271	34" x 2" x 72"	18	\$ 468
95436	18" x 2" x 80"	7	\$ 298	52354 *	34" x 2" x 80"	21	\$ 639
95437 *	18" x 2" x 93"	10	\$ 388	51305 *	34" x 2" x 93"	24	\$ 746

* Comes in two separate pieces to accommodate center posts.

Model No.	Size W-H-L	Ship Lbs.	List Price
b. EZ Panel Regulator Mount			
51956	4" x 10" x 36" (fits 42" shelf)	9	\$ 509
52446	4" x 10" x 48" (fits 54" shelf)	12	\$ 556
52264	4" x 10" x 54" (fits 60" shelf)	13	\$ 562
52284	4" x 10" x 66" (fits 72" shelf)	14	\$ 691
52049	4" x 10" x 74" (fits 80" shelf)	17	\$ 733
52050	4" x 10" x 87" (fits 93" shelf)	17	\$ 806

Model No.	Size W-H-L	Ship Lbs.	List Price
c. 1/2-Shelf — Double-Deep Units Only			
51412	34" x 3" x 42"	20	\$ 506
52437	34" x 3" x 54"	23	\$ 631
51273	34" x 3" x 60"	25	\$ 636
52355	34" x 3" x 72"	28	\$ 747
51274	34" x 3" x 80"	32	\$ 825
51276*	35 3/8" x 3" x 93"	36	\$1,004

* Requires Six Posts; This adds 1 3/8" to the overall depth.



▶ Keg Carrier

Model No.	Size W-H-L	Ship Lbs.	List Price
Holds (5) 15.5 Gallon, Half-Barrel Kegs			
51753	21 1/2" x 4 1/4" x 54 3/8"	8	\$ 220
Holds (15), Sixth-Barrel (Craft) Kegs			
52064	21 1/2" x 3 3/8" x 58 1/4"	13	\$ 365

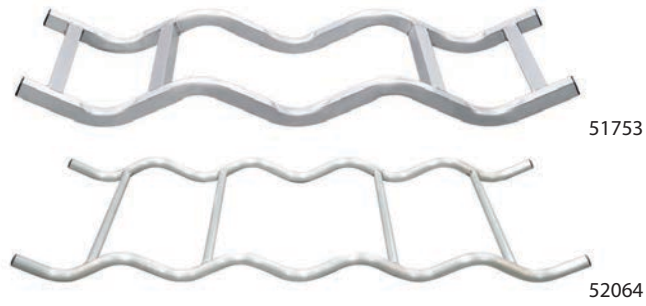

52064 - Shown on BDT18568 (pg 63)

51753 - Shown on BDT18568 (pg 63)

▶ Keg Dolly

Model No.	Size W-H-L	Weight Capacity	Ship Lbs.	List Price
98037	17 1/4" x 5 1/4" x 17 1/4"	175 lbs.	13	\$ 355

Accommodates 1/4 and 1/2 Barrel Kegs up to 16 3/4" in diameter.
Four 3" plate type swivel casters.

- Low profile helps reduce back injury.
- Lifetime Guarantee against rust and corrosion.



98037



Security



Standard Security Fence shown with "DSD" Option



Redesigned with "Easy Glide" Slides



Standard Security Fence - Left Hinge

Units Are Mounted To The Floor and Ceiling

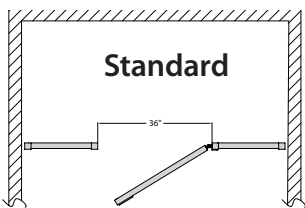

Standard

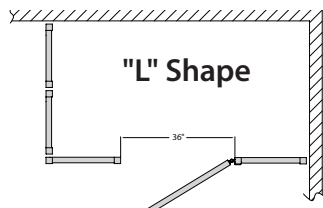

"L" Shape

Several Fence Configurations Are Available

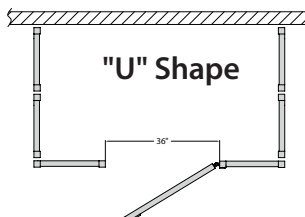

"U" Shape

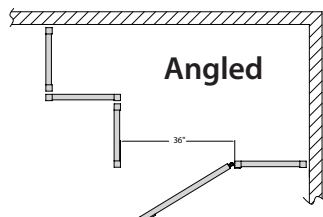

Angled

Aluminum Security Fence

If the Security Fence falls within the **specified parameters**, with a **center door**:

Opening Width = 68"-114" • Opening Height = 88"-110"

The Price Will Be = **\$5,233.00 list**
(subject to review)

Safety Option:

Inside Latch - Add Suffix "XH"

(Standard Door Only)

Allows someone locked inside to escape without tools.

Upgrade add-on = **\$510 list**

Sliding Door Options:

Sliding Double Door - Add Suffix "DSD"

Optional sliding double door for security fence, padlock holes in door handles for locking, approximate door opening 45" x 82".

Upgrade add-on = **\$4,771 list**

Sliding Single Door - Add Suffix "SSD"

Optional sliding single door for security fence, padlock hole from door handle to frame for locking, approximate door opening 29" x 82".

Upgrade add-on = **\$3,838 list**

Options may not be NSF Certified. Contact the factory.

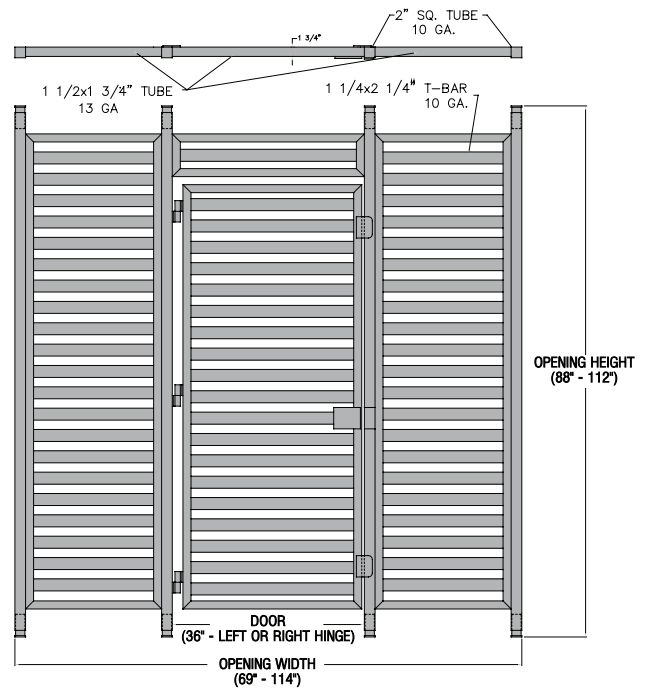

- Will not corrode like wire fencing.
- Additional Locking Options Available - *Contact the factory.*

EACH FENCE NEEDS A CUSTOM QUOTE. When requesting a Security Fence, we need the **WIDTH & HEIGHT of the opening** for the fence along with the **HINGE POSITION** (left or right). If there are special conditions such as a Ceiling Mounted Condenser or some other object that would require the fence to be modified, we need these dimensions to quote the fence.



Note: Actual fence width is 2" less than the opening width. These Cages are built-to-order and cannot be returned.

▶ Aluminum Security Cage

Model No.	Size W-H-D	Interior Shelves	Shelf Size	Clear Space	Ship Lbs.	List Price
Mobile Security Cage						
97621	49" x 71" x 26¾"	3	23½" x 45¾"	19"	170	\$ 8,001
Four 5" plate type swivel casters.						
Stationary Security Cage						
97846	48" x 72" x 24"	4	22" x 45"	14"	155	\$ 6,805
Equipped with four adjustable feet.						
Solid Security Cage With Vents						
98167	49¼" x 70½" x 25½"	3	24" x 45"	19"	190	\$ 7,610
Four 5" plate type swivel casters.						
Solid Security Cage With Adjustable Shelves						
99551	37¼" x 72¾" x 26"	3	22½" x 35"	Adj.	175	\$ 9,692
Four 5" plate type swivel casters.						



97621



97846

Options: Options may not be NSF Certified. Contact the factory.

Prison Package - Add "PP" suffix to model #\$ 442

- Provides safe, lockable security of valuable and/or dangerous materials.
 - Ideal "emergency box" for schools
 - Use for chemical storage
- Equipped with double doors with a stainless steel hasp and replaceable stainless steel hinges.
- All welded aluminum construction.
- Lifetime Guarantee against rust and corrosion.

! These Cages are built-to-order and cannot be returned.



98167



99551



Tables



Solid Poly Top



Stainless Steel Top
With Backsplash



Solid Poly Top
w/ Backsplash & Undershelf



► Poly Top Tables

Model No.	Size D-H-L	Ship Lbs.	List Price	Model No.	Size D-H-L	Ship Lbs.	List Price	Model No.	Ship Lbs.	List Price	
Solid PolyTop -- No Backsplash				Poly Top With 6" Stainless Steel Backsplash				Undershelf			
24P36KD	24" x 35½" x 36"	50	\$ 1,350	24PBS36KD	24" x 35½" x 36"	60	\$ 1,625	24US36KD	8	\$ 388	
24P48KD	24" x 35½" x 48"	59	\$ 1,615	24PBS48KD	24" x 35½" x 48"	68	\$ 1,838	24US48KD	11	\$ 424	
24P60KD	24" x 35½" x 60"	73	\$ 1,869	24PBS60KD	24" x 35½" x 60"	73.5	\$ 2,131	24US60KD	14	\$ 484	
24P72KD	24" x 35½" x 72"	86	\$ 1,932	24PBS72KD	24" x 35½" x 72"	101	\$ 2,319	24US72KD	17	\$ 444	
24P84KD	24" x 35½" x 84"	99	\$ 2,319	24PBS84KD	24" x 35½" x 84"	106	\$ 2,813	24US84KD	19	\$ 734	
24P96KD	24" x 35½" x 96"	106	\$ 2,401	24PBS96KD	24" x 35½" x 96"	111	\$ 2,828	24US96KD	22	\$ 799	
30P36KD	30" x 35½" x 36"	55	\$ 1,460	30PBS36KD	30" x 35½" x 36"	60	\$ 1,843	30US36KD	10	\$ 421	
30P48KD	30" x 35½" x 48"	71	\$ 1,627	30PBS48KD	30" x 35½" x 48"	85	\$ 1,923	30US48KD	13	\$ 466	
30P60KD	30" x 35½" x 60"	80	\$ 1,930	30PBS60KD	30" x 35½" x 60"	97	\$ 2,397	30US60KD	17	\$ 528	
30P72KD	30" x 35½" x 72"	100	\$ 2,021	30PBS72KD	30" x 35½" x 72"	108	\$ 2,516	30US72KD	20	\$ 581	
30P84KD	30" x 35½" x 84"	104	\$ 2,446	30PBS84KD	30" x 35½" x 84"	120	\$ 3,114	30US84KD	23	\$ 728	
30P96KD	30" x 35½" x 96"	115	\$ 2,333	30PBS96KD	30" x 35½" x 96"	132	\$ 3,102	30US96KD	27	\$ 814	

► Stainless Steel Top Tables

Model No.	Size D-H-L	Ship Lbs.	List Price	Model No.	Size D-H-L	Ship Lbs.	List Price	Model No.	Ship Lbs.	List Price	
Solid Stainless Steel Top -- No Backsplash				Stainless Steel Top With 6" Backsplash				Undershelf			
24SS36KD	24" x 35½" x 36"	46	\$ 1,730	24SSB36KD	24" x 35½" x 36"	49	\$ 1,960	24US36KD	8	\$ 388	
24SS48KD	24" x 35½" x 48"	59	\$ 1,944	24SSB48KD	24" x 35½" x 48"	61	\$ 2,218	24US48KD	11	\$ 424	
24SS60KD	24" x 35½" x 60"	74	\$ 2,210	24SSB60KD	24" x 35½" x 60"	77	\$ 2,480	24US60KD	14	\$ 484	
24SS72KD	24" x 35½" x 72"	81	\$ 2,524	24SSB72KD	24" x 35½" x 72"	88	\$ 2,571	24US72KD	17	\$ 444	
24SS84KD	24" x 35½" x 84"	112	\$ 2,793	24SSB84KD	24" x 35½" x 84"	115	\$ 2,889	24US84KD	19	\$ 734	
24SS96KD	24" x 35½" x 96"	116	\$ 3,096	24SSB96KD	24" x 35½" x 96"	119	\$ 3,100	24US96KD	22	\$ 799	
30SS36KD	30" x 35½" x 36"	51	\$ 1,997	30SSB36KD	30" x 35½" x 36"	52	\$ 1,735	30US36KD	10	\$ 421	
30SS48KD	30" x 35½" x 48"	63	\$ 2,213	30SSB48KD	30" x 35½" x 48"	65	\$ 2,012	30US48KD	13	\$ 466	
30SS60KD	30" x 35½" x 60"	71	\$ 2,461	30SSB60KD	30" x 35½" x 60"	80	\$ 2,354	30US60KD	17	\$ 528	
30SS72KD	30" x 35½" x 72"	87	\$ 2,580	30SSB72KD	30" x 35½" x 72"	95	\$ 2,580	30US72KD	20	\$ 581	
30SS84KD	30" x 35½" x 84"	101	\$ 2,914	30SSB84KD	30" x 35½" x 84"	110	\$ 2,914	30US84KD	23	\$ 728	
30SS96KD	30" x 35½" x 96"	114	\$ 3,179	30SSB96KD	30" x 35½" x 96"	125	\$ 3,179	30US96KD	27	\$ 814	

▶ Table Accessories

Model No.	Item Description	Size	Ship Lbs.	List Price
Table Accessories				
1375	Paper Holder	12" x 5" x 31"	3	\$ 141
1376	Platter Holder	30" x 24"	17	\$ 576
1377	Drawer/Hardware	15" x 18"	10	\$ 568
1379	S.S. Backsplash 6" x 6"	36"	14	\$ 432
1380	S.S. Backsplash 6" x 6"	48"	16	\$ 461
1381	S.S. Backsplash 6" x 6"	60"	19	\$ 589
1382	S.S. Backsplash 6" x 6"	72"	22	\$ 658
1383	S.S. Backsplash 6" x 6"	84"	25	\$ 982
1384	S.S. Backsplash 6" x 6"	96"	28	\$ 867

#1376 Fits 30" deep tables only.

Not NSF Certified.

Note: Casters Are Factory Installed Only.



▶ Cantilever Overshelves

Model No.	Item Description	Ship Lbs.	List Price
99653	12" x 36" SS Shelf, Posts & Brackets	25	\$ 1,416
99654	12" x 36" SS Shelf	16	\$ 1,102
99821	12" x 48" SS Shelf, Posts & Brackets	34	\$ 1,463
99822	12" x 48" SS Shelf	22	\$ 1,160
99823	12" x 60" SS Shelf, Posts & Brackets	43	\$ 1,758
99824	12" x 60" SS Shelf	28	\$ 1,473
99825	12" x 72" SS Shelf, Posts & Brackets	51	\$ 2,048
99826	12" x 72" SS Shelf	37	\$ 1,765

Not NSF Certified.



▶ Boat Racks

Model No.	Size D-H-L	Ship Lbs.	List Price
Table Mount Boat Racks			
120T	15" x 21¼" x 36"	16	\$ 674
1371T	15" x 21¼" x 48"	24	\$ 758
1372T	15" x 21¼" x 60"	21	\$ 852
1373T	15" x 21¼" x 72"	22	\$ 1,053
1374T	15" x 21¼" x 96"	27	\$ 1,188
1375T	15" x 21¼" x 120"	30	\$ 1,357
Wall Mount Boat Racks			
120W	15" x 21¼" x 36"	11	\$ 547
1371W	15" x 21¼" x 48"	14	\$ 671
1372W	15" x 21¼" x 60"	18	\$ 733
1373W	15" x 21¼" x 72"	19	\$ 988
1374W	15" x 21¼" x 96"	22	\$ 1,129
1375W	15" x 21¼" x 120"	29	\$ 1,270
Ceiling Mount Boat Racks — "L" Type			
1373CL	15" x 21¼" x 72"	25	\$ 1,193
1374CL	15" x 21¼" x 96"	28	\$ 1,325
Ceiling Mount Boat Racks — "T" Type			
1373CT	29" x 21¼" x 72"	36	\$ 1,831
1374CT	29" x 21¼" x 96"	41	\$ 2,233

All Boat Racks Include Mounting Brackets.

Options:

1378 Boat Rack Divider - Not NSF Certified... \$ 77

Wall Mount Boat Rack

- Structural aluminum mesh creates back and base.
- Allows easy cleaning.



Ceiling Mount Boat Rack - "L"

- Structural aluminum mesh with "L" type shelf, vertically adjustable telescoping mount.



Ceiling Mount Boat Rack - "T"

- Structural aluminum mesh with "T" type shelf, vertically adjustable telescoping mount.
- Storage on front and back of unit.



Accessories

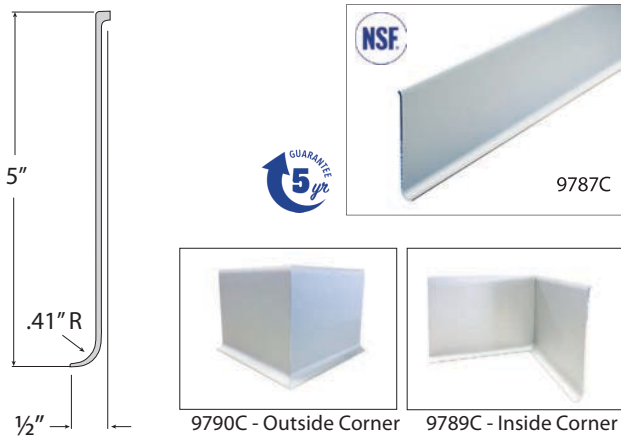

▶ Aluminum Cove Baseboard

Model No.	Length	Height	Ship Lbs.	List Price
Cove Baseboard - NSF Certified.				
9787C	96"	5"	4.65	\$ 167
Inside Corner - (2) Pieces - Not NSF Certified				
9789C	5"	5"	1	\$ 40
Outside Corner - (2) Pieces - Not NSF Certified				
9790C	5"	5"	1	\$ 40

- Solid anodized aluminum keeps its good looks and cleans up with just soap and water.
- Use instead of quarry tile or vinyl.
- Due to its natural propensity to ward off rust and corrosion, this baseboard is perfect for any type of atmosphere.
- Easy to install.

▶ Aluminum Glove Box Holder

Model No.	Size W-L-D	Holds Boxes	Ship Lbs.	List Price
98144	5 5/16" x 9 3/4" x 3 15/16"	up to 5"W x 3 3/4"D	3	\$ 89

Not NSF Certified.

- Items traditionally manufactured in stainless steel but can be made from aluminum at a more economic price point.

▶ Corner Guards

Model No.	Length	Ship Lbs.	List Price
2" x 2" Wings 90°			
97873	36"	1.5	\$ 87
97874	48"	1.9	\$ 101
97875	60"	5	\$ 109
97876	72"	5.5	\$ 117
3" x 3" Wings 90°			
97877	36"	3.5	\$ 108
97878	48"	4	\$ 119
97879	60"	5.5	\$ 137
97880	72"	6	\$ 151

.080" Thick Aluminum Sheet.

Not NSF Certified.



▶ Equipment Stand - Heavy Duty

Model No.	Size W-H-D	Top Style	Ship Lbs.	List Price
24ESS29	24" x 24" x 29"	Stainless	31	\$1,091
24ESA29	24" x 24" x 29"	Aluminum	22.5	\$ 933

Units equipped with NSF Certified adjustable feet.

Options: Options may not be NSF Certified. Contact the factory.

Aluminum Undershef - Add "US" suffix to model #\$ 147

Casters - Add suffix "999" to model #.....\$ 357

- All swivel with brake • Height with casters = 24".

** Casters Are Factory Installed Only **

98144



24ESS29999 | Stand with optional casters



► Equipment Stand - Standard

Model No.	Size D-H-L	Ship Lbs.	List Price	Model No.	Size D-H-L	Ship Lbs.	List Price
Stationary Units - Aluminum Top				Stationary Unit w/ Aluminum Top & Undershelf			
12436GS	24" x 24" x 36"	27.5	\$ 1,053	12436GSU	24" x 24" x 36"	37	\$ 1,307
12448GS	24" x 24" x 48"	32	\$ 1,113	12448GSU	24" x 24" x 48"	45	\$ 1,427
12460GS	24" x 24" x 60"	37	\$ 1,244	12460GSU	24" x 24" x 60"	51.5	\$ 1,535
12472GS	24" x 24" x 72"	45	\$ 1,860	12472GSU	24" x 24" x 72"	55	\$ 2,504
13036GS	30" x 24" x 36"	31	\$ 1,178	13036GSU	30" x 24" x 36"	43	\$ 1,466
13048GS	30" x 24" x 48"	37	\$ 1,220	13048GSC	30" x 24" x 48"	50	\$ 1,566
13060GS	30" x 24" x 60"	50	\$ 1,423	13060GSU	30" x 24" x 60"	62	\$ 1,797
13072GS	30" x 24" x 72"	55	\$ 1,561	13072GSU	30" x 24" x 72"	66	\$ 2,032



13036GSCUSR

Model No.	Size D-H-L	Ship Lbs.	List Price	Model No.	Size D-H-L	Ship Lbs.	List Price
Mobile Unit - Aluminum Top				Mobile Unit w/ Aluminum Top & Undershelf			
12436GSC	24" x 24" x 36"	38	\$ 1,285	12436GSCU	24" x 24" x 36"	44	\$ 1,481
12448GSC	24" x 24" x 48"	40	\$ 1,432	12448GSCU	24" x 24" x 48"	51	\$ 1,621
12460GSC	24" x 24" x 60"	47	\$ 1,557	12460GSCU	24" x 24" x 60"	57	\$ 1,735
12472GSC	24" x 24" x 72"	52	\$ 1,998	12472GSCU	24" x 24" x 72"	70	\$ 2,477
13036GSC	30" x 24" x 36"	41	\$ 1,389	13036GSCU	30" x 24" x 36"	51	\$ 1,598
13048GSC	30" x 24" x 48"	50	\$ 1,498	13048GSCU	30" x 24" x 48"	57	\$ 1,766
13060GSC	30" x 24" x 60"	52	\$ 1,604	13060GSCU	30" x 24" x 60"	71	\$ 1,903
13072GSC	30" x 24" x 72"	59	\$ 1,886	13072GSCU	30" x 24" x 72"	82	\$ 2,118



12448GSC

Four 5" stem type casters.
Weight Capacity = 1000 lbs.

Options: Options may not be NSF Certified. Contact the factory.

Sandwich Rail - Add "SR" suffix to model #.

- 36" long \$ 493
- 48" long \$ 576
- 60" long \$ 826
- 72" long \$ 920

Note: Must use same length sandwich rail as Equipment Stand.
Other options available - Contact factory for quote.



21524ES24P • 21524ES24PC

► Modular Aluminum Equipment Stand

Model No.	Size D-H-L	Ship Lbs.	List Price	Model No.	Size D-H-L	Ship Lbs.	List Price	Model No.	Size D-H-L	Ship Lbs.	List Price
21524ES24P	15" x 24" x 24"	15	\$ 698	21524ES30P	15" x 30" x 24"	17	\$ 710	21524ES36P	15" x 36" x 24"	17	\$ 729
21530ES24P	15" x 24" x 30"	22	\$ 710	21530ES30P	15" x 30" x 30"	19	\$ 698	21530ES36P	15" x 36" x 30"	20	\$ 729
21536ES24P	15" x 24" x 36"	19	\$ 750	21536ES30P	15" x 30" x 36"	20	\$ 760	21536ES36P	15" x 36" x 36"	21	\$ 781
21542ES24P	15" x 24" x 42"	20	\$ 788	21542ES30P	15" x 30" x 42"	21	\$ 798	21542ES36P	15" x 36" x 42"	22.5	\$ 818
21548ES24P	15" x 24" x 48"	23	\$ 805	21548ES30P	15" x 30" x 48"	24	\$ 816	21548ES36P	15" x 36" x 48"	25	\$ 836
21824ES24P	18" x 24" x 24"	17	\$ 679	21824ES30P	18" x 30" x 24"	18	\$ 689	21824ES36P	18" x 36" x 24"	19	\$ 710
21830ES24P	18" x 24" x 30"	19.5	\$ 679	21830ES30P	18" x 30" x 30"	20.5	\$ 689	21830ES36P	18" x 36" x 30"	22	\$ 710
21836ES24P	18" x 24" x 36"	22	\$ 628	21836ES30P	18" x 30" x 36"	22.5	\$ 639	21836ES36P	18" x 36" x 36"	24.5	\$ 628
21842ES24P	18" x 24" x 42"	23.5	\$ 747	21842ES30P	18" x 30" x 42"	24.5	\$ 785	21842ES36P	18" x 36" x 42"	25.5	\$ 758
21848ES24P	18" x 24" x 48"	27.5	\$ 696	21848ES30P	18" x 30" x 48"	28.5	\$ 707	21848ES36P	18" x 36" x 48"	29.5	\$ 727
22024ES24P	20" x 24" x 24"	20	\$ 714	22024ES30P	20" x 30" x 24"	21	\$ 725	22024ES36P	20" x 36" x 24"	22	\$ 745
22030ES24P	20" x 24" x 30"	22	\$ 714	22030ES30P	20" x 30" x 30"	23	\$ 725	22030ES36P	20" x 36" x 30"	24	\$ 745
22036ES24P	20" x 24" x 36"	25.5	\$ 654	22036ES30P	20" x 30" x 36"	24.5	\$ 663	22036ES36P	20" x 36" x 36"	25	\$ 684
22042ES24P	20" x 24" x 42"	25.5	\$ 745	22042ES30P	20" x 30" x 42"	26	\$ 754	22042ES36P	20" x 36" x 42"	27	\$ 776
22048ES24P	20" x 24" x 48"	31	\$ 691	22048ES30P	20" x 30" x 48"	28.5	\$ 702	22048ES36P	20" x 36" x 48"	33	\$ 722

Not NSF Certified.

Options:

Castors (4): Add "C" suffix to model #... \$ 285
– Stem type swivel casters with brake.

Note: This option adds 6" to the overall height of the unit.



Carts & Trucks

► Produce/Stocking Cart

Model No	Size W-H-L	Weight Capacity	Number Of Casters	Top Shelf Height	Shelf Spacing	Ship Lbs.	List Price
Solid Top Shelf • T-Bar Bottom Shelf							
1415	19" x 30" x 41"	800 lbs.	4	30"	20"	43	\$1,106
Solid Top Shelf • T-Bar Bottom Shelf w/ Handle							
1416	19" x 42" x 48"	800 lbs.	4	30"	20"	46	\$1,143
T-Bar Top & Bottom Shelf w/ Handle							
1420	19" x 42" x 48"	1000 lbs.	4	30"	20"	45	\$ 996
Solid Top & Bottom Shelf w/ Handle							
1490	19" x 39" x 48"	800 lbs.	6	30"	20"	55	\$1,351
Solid Top & Bottom Shelf w/ Handle - "Floral Cart" - Not NSF Certified							
NS765	18½" x 32" x 45"	500 lbs.	4	32"	22½"	43	\$1,443

Model #1415, #1416 & #1420: Four 5" plate type casters; two swivel, two rigid.

Model #1490: Six 5" plate type casters; four swivel, two rigid.

Model #NS765: Four 5" plate type swivel casters.

Options: ***FACTORY INSTALLED ONLY*** Options may not be NSF Certified. Contact the factory.

"CL(B)", "PB" — See page 71 for details.

- These all welded units provide maximum strength and durability.
- Raised marine edge on solid shelves contains spills.
- T-Bar type shelves provide air circulation.
- Lifetime Guarantee against rust and corrosion.
- NSF Certified. (Excluding model #NS765)



1415



1416



1490



1420



NS765



Spill Containing Shelves



► Heavy Duty Stock Truck

Model No	Size W-H-L	Weight Capacity	Top Shelf Type	Top Shelf Height	Shelf Spacing	Ship Lbs.	List Price
NS557	21" x 44" x 59½"	3000 lbs.	Bar	30"	18"	62	\$1,357
Unit With Solid Aluminum Top - Not NSF Certified.							
NS557A	21" x 44" x 59½"	3000 lbs.	Solid	30"	18"	65	\$1,788

Two tier unit with handle.

Four 6" x 2" plate type casters; two swivel with brake, two rigid.

Options: Options may not be NSF Certified. Contact the factory.

"B", "PB", "VB" -- See page 71 for details.

- For use in any application that requires maximum strength and durability.
- All welded aluminum construction with four, 6" x 2" plate type casters.
- 3,000 lbs. Weight capacity.
- Lifetime Guarantee against rust and corrosion.
- NSF Certified.



NS557



► Tubular Deck Cart

Model No	Size W-H-L	Weight Capacity	Top Shelf Height	Shelf Spacing	Ship Lbs.	List Price
95661	19" x 42" x 45"	700 lbs.	30"	20¾"	40	\$ 999

Four 5" plate type casters; two swivel, two rigid.

Options: Options may not be NSF Certified. Contact the factory.

"CL(B)" — See page 71 for details.

- Double-deck cart moves product at a convenient, workable height from the floor.
- Perfect for narrow aisles with a width of 19".
- All-welded construction provides for heavy duty stocking and produce operations.
- NSF Certified.



95661



► Utility Stock Truck

Model No	Size W-H-L	Weight Capacity	Top Shelf Height	Shelf Spacing	Ship Lbs.	List Price
96134BH	21" x 41½" x 47"	700 lbs.	30"	20¾"	42	\$ 1,036

Four 5" plate type swivel casters.

Top shelf measures 19"W x 40"L without bumpers.

Handle and Corner Bumpers are standard equipment.

- Double-deck stock truck moves product at a convenient, workable height from the floor.
- Perfect for narrow aisles with a width of 19".
- All-welded construction provides for heavy duty stocking and produce operations.



96134BH



Produce Carts



1408 • 1410



► Wet Produce Cart - Heavy Duty

Model No	Size W-H-L	Weight Capacity	Number Of Casters	Top Shelf Height	Shelf Spacing	Ship Lbs.	List Price
Carts w/ Two (2) Removable Pans							
1408	21" x 41" x 48½"	1200 lbs.	6	30"	19¼"	64	\$1,748
1410	29" x 41" x 50½"	1000 lbs.	6	30"	19¼"	69	\$2,012

Above units come equipped with a full perimeter bumper on the top shelf.
Six 5" plate type casters; four swivel, two rigid.

Options: Options may not be NSF Certified. Contact the factory.

"CL(B)" - See page 71 for details.

- This Wet Produce Truck helps minimize the mess of transporting produce by retaining moisture and debris.
- With two reinforced removable drip pans, this unit allows you to contain as well as remove unwanted moisture promoting a clean, sanitary area.
- Each removable shelf is reinforced with a heavy-duty, channel-enforced frame supported by four sturdy posts (one located at each corner).
- NSF Certified.

► Wet Produce Cart - Standard

Model No	Size W-H-L	Weight Capacity	Number Of Casters	Top Shelf Height	Shelf Spacing	Ship Lbs.	List Price
Cart w/ One (1) Removable Pan							
97126	24¾" x 38" x 52"	700 lbs.	4	30"	20"	52	\$1,241

Above unit has removable pan on top shelf with heavy duty tubular base.
Four 5" plate type casters; two swivel, two rigid.

Options: Options may not be NSF Certified. Contact the factory.

"B", "CL(B)", "PB" -- See page 71 for details.

- Double-deck cart moves product at a convenient, workable height from the floor.
- Perfect for narrow aisles with a width of 24¾".
- All-welded construction provides for heavy duty stocking and produce operations.
- NSF Certified.



97126



► Produce Crisping Cart

Model No.	Size W-H-L	Basket Capacity	Runner Spacing	Ship Lbs.	List Price
Stationary Unit- Equipped With Drip Pan & Adjustable Feet					
1315	32½" x 81½" x 26"	8	10¾"	42	\$1,004
Mobile Units - Equipped With Drip Pan					
1316	32½" x 86½" x 26"	8	10¾"	60	\$1,243
95136	32½" x 76" x 26"	7	10¾"	58	\$1,175
Crisping Basket - Not NSF Certified					
0307	26" x 9" x 29"			8	\$ 207

Mobile units: Four 5" plate type casters; two swivel, two swivel with brake.

All units accept Nestier, Buckhorn®, and Lewis chill baskets 26" x 29".

- Allows quick, easy access to all crisping baskets.
- Mobile unit can be filled in prep area and rolled into the cooler.
- Lifetime Guarantee against rust and corrosion, superior for coolers and freezers.
- NSF Certified.



1316



► Mobile Merchandiser

Model No.	Position	Size L-H-W	Weight Capacity	Ship Lbs.	List Price
1407	Upright / Display	43" x 43½" x 24"	1000 lbs.	45	\$ 1,249
	Flat / Storage	48" x 19" x 24"			

Four heavy duty, plate casters with Polyurethane tread; two: 2" x 5" rigid with brake, 1¾" x 5" swivel.

- Show off your merchandise, not your merchandiser.
- Vertical adjustment from flat, to 30° to 45° degrees providing three different, attractive displays.
- Folds flat and stores upright to save space.
- Use multiple units to create larger displays.
- Has 8 square feet of merchandising area... Takes up 3½ square feet of storage space.
- Lifetime Guarantee against rust and corrosion.



1407



Lug Dollies

► Lug Dollies - Heavy Duty



Model No.	Size W-H-D	Lug Capacity	Ship Lbs.	List Price
Heavy Duty - Accepts 15½" x 8¾" x 25" Lug (Not Included)				
1261	18⅞" x 27½" x 21"	2	24	\$ 609
1262	18⅞" x 52" x 26½"	4	36	\$ 826
1263	18⅞" x 72" x 26½"	6	40	\$ 965
1264	29½" x 62" x 33"	10	48	\$ 1,189

Model #1261 Requires Stacking Lugs.

#1261, #1262, & #1263: Four 5" plate type swivel casters.

#1264: Four 5" plate type casters; two swivel, two rigid.

Options: Options may not be NSF Certified. Contact the factory.

"CL(B)" (#1261, #1262 & #1263 only) - See page 71 for details.

Model	Size W-H-D	Lug Capacity	Ship Lbs.	List Price
Standard - Accepts 15½" x 8¾" x 25" Lug (Not Included)				
1265	16¾" x 19" x 26"	1	11	\$ 268
1266	16¾" x 33" x 29¼"	2	18	\$ 433
99304*	17¼" x 41½" x 28"	3	21	\$ 779
1267	Handle for #1265 & #1266 (bolted on)			\$ 116

Standard - With Welded Handle

1265H*	16¾" x 36½" x 28¾"	1	14	\$ 389
1266H*	16¾" x 36½" x 30½"	2	17.5	\$ 538

Four 5" stem type swivel casters.

* Not NSF Certified.

Options: Options may not be NSF Certified. Contact the factory.

"CL(A)", "MD" - See page 71 for details.



► Lug Dollies - Economy

Model No.	Lug Cap.	Size W-H-D	Ship Lbs.	List Price
6265	1	16¾" x 19" x 26"	10	\$ 235
6266	2	16¾" x 33" x 29¼"	16	\$ 338
97205*	3	18⅞" x 42" x 26"	23	\$ 467
6262	4	18⅞" x 51" x 26"	25	\$ 620
97253*	5	18⅞" x 61" x 26"	28	\$ 632
6263	6	18⅞" x 71" x 26"	31	\$ 632

Four 5" stem type swivel casters.

* Not NSF Certified.

Options: Options may not be NSF Certified. Contact the factory.

"CL(A)" - See page 71 for details.

- Accepts standard lugs (15½"W x 8¾"H x 25"L).
- Ideal for bulk food transporting.
- NSF Certified.



Bulk Cart • Frame & Tubs

Model No.		Size W-H-D	Ship Lbs.	List Price
***** All Items Are Sold Separately *****				
a. 2¼ Bushel • 16.5 Gallon				
99521	Dolly	20¼" x 33" x 26¼"	26	\$ 639
0300	Tub	19¼" x 13¾" x 26"	8	\$ 295
b. 4 Bushel • 30 Gallon				
99271	Dolly	21" x 28¼" x 30¼"	22	\$ 564
0381	Tub	21¼" x 15¾" x 32¾"	12	\$ 535
0381L	Lid	22½" x 2" x 34"	9	\$ 261
c. 6 Bushel • 41 Gallon				
99272	Dolly	22" x 25" x 29"	22	\$ 593
0363	Tub	23¼" x 20" x 32¼"	17	\$ 634
0363L	Lid	24½" x 2" x 33½"	6	\$ 290
d. 8 Bushel • 57 Gallon				
99273	Dolly	23¼" x 24" x 34½"	23	\$ 602
0360	Tub	24½" x 23" x 36¼"	23	\$ 713
0360L	Lid	25" x 2½" x 37½"	12.5	\$ 350
e. 9 Bushel • 66 Gallon				
99274	Dolly	27½" x 25" x 38¼"	26	\$ 637
0382	Tub	29½" x 19" x 41½"	27	\$ 793
0382L	Lid	29½" x 2½" x 41½"	10	\$ 348

Four 5" stem type swivel casters.
All carts with tubs are 36½" high.

Options: Options may not be NSF Certified. Contact the factory.
"CL(A)" - See page 71 for details.



Lid



- The perfect "bulk" cart for every department.
- All welded construction.
- Lifetime Guarantee against rust and corrosion.

Note: Tubs and Lids are excluded from guarantees.



Mega Movers

Model No.		Size W-H-L	Ship Lbs.	List Price
***** All Items Are Sold Separately *****				
f. 14 Bushel • 17 Cubic Feet • 115 Gallon				
51619	Dolly	24½" x 8" x 36½"	30	\$ 856
0814	Tub	32" x 27½" x 44"	35	\$ 987
(Tub on Dolly = 35¾"H)				
g. 16 Bushel • 18.6 Cubic Feet • 135 Gallon				
51620	Dolly	24½" x 9" x 36½"	30	\$ 861
0816	Tub	32" x 30" x 44"	38	\$1,053
(Tub on Dolly = 36¾"H)				
h. 18 Bushel • 24 Cubic Feet • 155 Gallon				
51621	Dolly	26½" x 9" x 38¾"	31	\$ 870
0818	Tub	34" x 30" x 46"	41	\$1,186
(Tub on Dolly = 38¼"H)				
i. 20 Bushel • 25.6 Cubic Feet • 170 Gallon				
51622	Dolly	28½" x 9" x 44½"	33	\$ 878
0820	Tub	36" x 31" x 52"	46	\$1,266
(Tub on Dolly = 39¾"H)				

Six 5" plate type casters; four swivel, two rigid.



Base



Tubs

Tub and Base are not joined for easy cleaning.

Aluminum Base

- Lifetime Guarantee against rust and corrosion.
- Six wheel design allows for zero turning radius.
- 1500 lbs. Weight Capacity

FDA Tubs

- FDA Compliant tubs.
- Heavy wall in "all natural white" color.
- Seamless molded Polyethylene body.
- Smooth finish with rounded corners.

Note: Tubs and Lids are excluded from guarantees.

Universal Carts

▶ Universal Lug Dolly

Model No.	Size W-H-D	Lug Capacity	Between Shelf Space	Ship Lbs.	List Price
1276	18½" x 36" x 26"	3	10"	26	\$ 672
1277	18½" x 47" x 26"	4	10"	30	\$ 728
1279	18½" x 68" x 26"	6	10"	35	\$ 768

Four 5" stem type swivel casters.

Options: Options may not be NSF Certified. Contact the factory.

"CL(A)" - See page 71 for details.

- Designed to hold lugs by the bottom, not the lip allowing the storage of various sizes of lugs.
- Lifetime Guarantee against rust and corrosion.
- NSF Certified.



1279



1277



99251

▶ Lug Storage Dolly & Lugs

Model No.	Size W-H-D	With Handle	Ship Lbs.	List Price
99251	17" x 6" x 26"	No	13	\$ 278

Four 3" x 1¾" plate type swivel casters.

Not NSF Certified.

Model No.	Size W-H-L	Color	Ship Lbs.	List Price
RGY16825	15½" x 8¾" x 25"	gray	4	\$ 78
0361	Lid For #RGY16825	gray	1	\$ 70

Food Approved Molded Poly • Formed Cross-Stacking Bottom.

Not NSF Certified.

Note: Lugs and Lids are excluded from guarantees.



RGY16825



0361

► Universal Cart - Heavy Duty

Model No.	Size W-H-D	Number Of Shelves	Between Shelf Space	Ship Lbs.	List Price
1356	20 ⁷ / ₈ " x 67" x 27"	6	10 ¹ / ₂ "	47	\$1,102
1357 *	28 ¹ / ₂ " x 69" x 32"	7	9"	60	\$1,923
1358 **	20 ⁷ / ₈ " x 67" x 27"	8	7 ¹ / ₄ "	46	\$1,266

Four 5" plate type swivel casters.

* Model #1357 is a double capacity unit.

** Model #1358 will not accept lugs.

Options: Options may not be NSF Certified. Contact the factory.

"B", "CL(B)", "MD", "PB", "VB" — see page 71 for details.

PAN SIZES:

10" x 20" Roast & Bake Pans • 20" x 22" Roast & Bake Pans • 18" x 26" Roasting Pans • 18" x 26" Bun Pans • 18" x 13" Bun Pans • 12" x 20" Steam Table Pans • 20³/₄" x 25¹/₂" European Std. GastroNorm Pans • 15" x 20" Service Tray • 14" x 18" Service Tray • 20" x 20" Cup & Glass Racks

- Ideal multipurpose rack for all departments.
- Accepts many sizes of platters, pans, boxes and lugs.
- All welded construction with 5" platform type casters.
- Lifetime Guarantee against rust and corrosion.
- NSF Certified.



1357



► Universal Cart - Standard

Model No.	Size W-H-L	Pan Capacity	Runner Spacing	Ship Lbs.	List Price
For Platters, Pans, or Boxes Up To 18"W x 26"L					
1356M	20 ⁷ / ₈ " x 67" x 27"	6	10 ¹ / ₂ "	45	\$ 942

Four 5" stem type swivel casters.

Options: Options may not be NSF Certified. Contact the factory.

"CL(A)", "VB" - see page 71 for details.

PAN SIZES:

10" x 20" Roast & Bake Pans • 20" x 22" Roast & Bake Pans • 18" x 26" Roasting Pans • 18" x 26" Bun Pans • 18" x 13" Bun Pans • 12" x 20" Steam Table Pans • 20³/₄" x 25¹/₂" European Std. GastroNorm Pans • 15" x 20" Service Tray • 14" x 18" Service Tray • 20" x 20" Cup & Glass Racks

- Ideal for transporting various sized platters, trays, boxes, and lugs.
- Heavy duty extruded oval tubing shelves provide easy product access and selection.
- NSF Certified.



1356M



Platter Racks

▶ Platter Rack • Angle Guide - Heavy Duty



1348



1340

Model No	Size W-H-D	Platter Capacity	Platter Size	Runner Spacing	Ship Lbs.	List Price
----------	------------	------------------	--------------	----------------	-----------	------------

Single

Designed for 10" x 30" Platters

1340	13" x 39" x 30"	6	10" x 30"	5"	23	\$ 789
1343	13" x 69" x 30"	10	10" x 30"	6"	32	\$ 776
1345	13" x 69" x 30"	12	10" x 30"	5"	35	\$ 794

Designed for 12" x 30" Platters

1346	15¼" x 39" x 30"	6	12" x 30"	5"	24	\$ 668
1348	15¼" x 69" x 30"	10	12" x 30"	6"	43	\$ 735
1347	15¼" x 69" x 30"	12	12" x 30"	5"	43	\$ 794

Four 5" stem type swivel casters — "Single" units listed above.

Double

1349	25½" x 71½" x 30"	18	10" x 30"	7½"	70	\$ 1,507
1350	29½" x 71½" x 30"	18	12" x 30"	7½"	71	\$ 1,507

Four 5" plate type swivel casters — "Double" units listed above.

Options: Options may not be NSF Certified. Contact the factory.

Single: "CL(A)", "MD", "PS", "VB" - see page 71 for details.

Double: "B", "CL(B)", "MD", "PS" (requires two), "VB" - see page 71 for details.



▶ Platter Rack • Angle Guide - Standard



6347



6348

Model No.	Size W-H-D	Platter Size	Platter Capacity	Runner Spacing	Ship Lbs.	List Price
-----------	------------	--------------	------------------	----------------	-----------	------------

6345	13" x 69" x 30"	10" x 30"	12	5"	34	\$ 628
6348	15¼" x 69" x 30"	12" x 30"	10	6"	33	\$ 628
6347	15¼" x 69" x 30"	12" x 30"	12	5"	36	\$ 628

Four 5" stem type swivel casters.

Options: Options may not be NSF Certified. Contact the factory.

"CL(A)", "PS", "VB" - See page 71 for details.

- Ideal for platter transport to and from the meat department.
- Heavy duty extruded angles provide easy product access and selection.
- Approved for use in freezers, coolers, as well as packaging and storage areas.



► Heavy Duty Platter Rack

Model No	Size W-H-D	Platter Capacity	Platter Size	Runner Spacing	Ship Lbs.	List Price
1161	15¾" x 39½" x 26½"	6	12" x 26"	5"	30	\$ 886
1162	21" x 39½" x 26½"	6	18" x 26"	5"	30	\$ 855
1163	15¾" x 69½" x 26½"	12	12" x 26"	5"	42	\$1,012
1164	21" x 69½" x 26½"	12	18" x 26"	5"	52	\$1,012

Four 5" plate type swivel casters.

Options: Options may not be NSF Certified. Contact the factory.

"B", "CL(B)", "M6", "MD", "PB" - See page 71 for details.



1162



1164



► Universal Platter Rack - Heavy Duty

Model No.	Size W-H-D	Number Of Shelves	Between Shelf Space	Ship Lbs.	List Price
Accepts 10" x 30" or 12" x 30" Platters					
1354	16" x 42" x 32½"	5	7¼"	37	\$ 917
1355	16" x 67" x 32½"	8	7¼"	51	\$1,138

Four 5" plate type swivel casters.

Options: Options may not be NSF Certified. Contact the factory.

"B", "CL(B)", "MD", "PB", "VB" - See page 71 for details.



1355



1354



► Universal Platter Rack - Standard

Model No.	Size W-H-D	Number Of Shelves	Shelf Spacing	Ship Lbs.	List Price
For 10" - 12" Platters Up To 30" In Length					
6354	15½" x 42" x 32"	5	7¼"	34	\$ 858
1355M	15½" x 67" x 32"	8	7¼"	45	\$1,042

Four 5" stem type swivel casters.

Options: Options may not be NSF Certified. Contact the factory.

"CL(A)", "VB" - See page 71 for details.



1355M



6354



Folding Carts

► Folding Utility Cart

Model No.	Size Unfolded	Size Folded	Weight Capacity	Ship Lbs.	List Price
96856	16" x 64" x 64¾"	16" x 14" x 64¾"	1500 lbs.	76	\$1,502

Four 5" x 1¼" polyurethane, plate type swivel casters and two 6" x 2" polyurethane plate type rigid casters.

- **Effortless Stocking Capability**
 - Ideal for transporting heavy loads from the back room to the floor area or cooler.
 - Big enough to stock a complete area with one trip!
- **Completely Portable** - Six wheel design allows the unit to turn on a dime.
- **Guaranteed Maintenance Free**
 - **Lifetime Guarantee** against rust and corrosion.
 - **Five-Year Construction Guarantee.**
- **Maximum Storage Space**
 - Stores upright (on-end) to maximize available storage space.



96856



► Folding "L" Cart

Model No.	Size W-H-L	Deck Height	Number Of Casters	Ship Lbs.	List Price
95370	20" x 52¾" x 55¼"	9"	6	53	\$1,306
95241	18" x 63" x 62"	9½"	6	54	\$1,213

Six plate type casters; four 5" swivel and two 6" x 2" rigid.

- Folds up for easy storage.
- Has 7½ square feet of deck space... Takes up less than 2 square feet of storage space.
- **1200 lbs. Weight Capacity.**
- For transporting heavy loads from the back room to the floor.
- Lifetime Guarantee against rust and corrosion, superior for coolers & freezers.



95370

95241



► Low Boy Stock Cart

Model No.	Size W-H-L	Weight Capacity	Deck Height	Number Of Casters	Ship Lbs.	List Price
1183	16" x 41" x 54"	1000 lbs.	9½"	6	40.5	\$991
1184	14" x 40" x 39"	1000 lbs.	7¾"	4	23	\$740

Model #1183: Six plate type casters; four 5" swivel, two 6" rigid.

Model #1184: Four 5" plate type casters; two swivel, two rigid.

Each Unit Has A Removable Handle.

- Designed for transporting heavy loads from the backroom to the floor.
- Rounded front helps protect walls and displays.
- Lifetime Guarantee against rust and corrosion, superior for coolers & freezers.
- NSF Certified.



1184

1183



Bulk Delivery Truck

Model No.	Size W-H-L	Position	Weight Capacity	Ship Lbs.	List Price
BDT18568	18" x 63" x 61"	Unfolded	1200 lbs.	104	\$ 2,113
	18" x 17" x 61"	Folded			
Six 8" x 2" plate type casters; four swivel, two rigid					
BDT18566	18" x 61" x 61"	Unfolded	1200 lbs.	96	\$ 2,024
	18" x 15" x 61"	Folded			
Six 6" x 2" plate type casters; four swivel, two rigid.					

Options:

Removable Handle - Add "R" suffix to model #.....\$ 19

Dual Brake System - Add "B" suffix to model #.....\$ 186

For Center Rigid Wheels **** New Carts Only - Not for Retro-Fit ****

- Big enough to transport enough product to stock a complete area, this folding delivery truck allows quick, convenient stocking.
- Vertical cart storage allows 100% accessibility for your next delivery.
- Maneuverable —zero turning —easier for narrow aisles and coolers.
- Solid integrated deck.
- Center rigid casters allow for zero turning radius.
- Lifetime Guarantee against rust and corrosion.

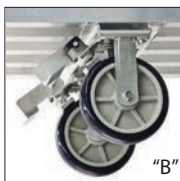

BDT18566



BDT18568

Aluminum Platform Truck

Model No.	Size W-H-L	Deck Size	Weight Capacity	Ship Lbs.	List Price
Platform Truck With Smooth Deck					
PT2436S6	24" x 41" x 39"	24" x 36"	2600 lbs.	54	\$ 1,634
PT2448S6	24" x 41" x 51"	24" x 48"	2600 lbs.	58	\$ 1,789
PT3048S6	30" x 41" x 51"	30" x 48"	2600 lbs.	65	\$ 1,938
PT3060S6	30" x 41" x 63"	30" x 60"	2600 lbs.	75	\$ 2,130
PT3660S6	36" x 41" x 63"	36" x 60"	2600 lbs.	89	\$ 2,318
PT3672S6	36" x 41" x 75"	36" x 72"	2600 lbs.	93	\$ 2,697
Platform Truck With Tread Plate Deck					
PT2436P6	24" x 41" x 39"	24" x 36"	2600 lbs.	56	\$ 1,773
PT2448P6	24" x 41" x 51"	24" x 48"	2600 lbs.	60	\$ 1,829
PT3048P6	30" x 41" x 51"	30" x 48"	2600 lbs.	67	\$ 2,056
PT3060P6	30" x 41" x 63"	30" x 60"	2600 lbs.	78	\$ 2,155
PT3660P6	36" x 41" x 63"	36" x 60"	2600 lbs.	89	\$ 2,548
PT3672P6	36" x 41" x 75"	36" x 72"	2600 lbs.	95	\$ 2,625

Four 6"x2" heavy duty polyurethane tread plate casters; 2 swivel, 2 rigid. Equipped with (1) handle, optional extra/replacement handles sold below.

Options:

"CL(C)", "PB", "PP(C)" - see page 71 for details.

Caster Upgrade -- Replace last digit of model # with "8".....\$ 70

Consists of four 8" x 2" heavy duty polyurethane tread plate casters — two swivel, two rigid.

Options: "CL(E)" — see page 71 for details.

Extra Handle

60328	For 24" Wide Units	11	\$ 167
60329	For 30" Wide Units	11.5	\$ 167
60330	For 36" Wide Units	13	\$ 167

Options:

Extra Handle Welded in Place - Add "PP" suffix to model #.



Smooth Deck



Tread Plate Deck (shown with caster upgrade)



Trucks



95762



96055 shown with two 96055RS



96055RS



1152



1430



► U-Boat

Model No	Size W-H-L	Weight Capacity	Ship Lbs.	List Price
U-Boats				
95762	18" x 52¼" x 60"	1500 lbs.	51	\$ 1,285
96055	20" x 52¼" x 60"	1500 lbs.	59	\$ 1,307

Six plate type casters; four 5" x 1¼" swivel, two 6"x 2" rigid.

Removable Shelves For U-Boats - Listed Above

95762RS	For #95762	13	\$ 447
96055RS	For #96055	15	\$ 422

Removable shelves are reinforced with a solid cover.

► Boxed Beef Truck

Model No	Size D-H-L	Number Of Shelves	Shelf Spacing	Ship Lbs.	List Price
1151	27" x 71" x 63"	2	29"	118	\$ 1,872
1152	27" x 71" x 63"	3	top= 28" bottom = 29"	123	\$ 2,100

Four 6" plate type casters; two swivel with brake, two rigid.

Options: Options may not be NSF Certified. Contact the factory.

"B", "PB", "&" "VB" — see page 71 for details.

- Use in coolers, freezers, and dry storage.
- Transport heavy loads up to 2,600 lbs.
- Heavy Duty 6" plate type casters.
- All welded, heavy duty aluminum construction.
- Lifetime Guarantee against rust and corrosion.
- NSF Certified.

► Uni-T Truck

Model No	Size D-H-L	Wheel Size	Shelf Spacing	Ship Lbs.	List Price
1430	24" x 68" x 58"	6"	38¼"	92	\$ 1,840
1431	24" x 70" x 58"	8"	38¼"	114	\$ 1,980

Model #1430: Four 6" plate type casters; two swivel, two rigid.

Model #1431: Four 8" plate type casters; two swivel, two rigid.

Options: Options may not be NSF Certified. Contact the factory.

"B", #1430=CL(C), #1431=CL(E) "PB", &" "VB" -- see page 71 for details.

- Use in coolers, freezers, and dry storage.
- Transport heavy loads up to 2,000 lbs.
- All welded, heavy duty aluminum construction.
- Lifetime Guarantee against rust and corrosion.
- NSF Certified.

▶ Wall Mount Mat Rack

Model No.	Size W-H-D	Weight Capacity	Ship Lbs.	List Price
52677	42" x 10" x 7"	**	17	\$ 522

** Determined by method of installation and type of wall

Labor saving mat rack keep mats off the floor for easy, efficient cleaning.

- Ideal for power washing.
- Hooks secure perforated mats for storage and cleaning.
- Lifetime Guarantee against rust and corrosion.



52677

Like all New Age products, the Mat Rack can be easily customized to accommodate your mat. All you need to get started is a few key measurements.

1. Length and Width of mat.
2. Diameter of holes in the mat.
3. Mat hole spacing.

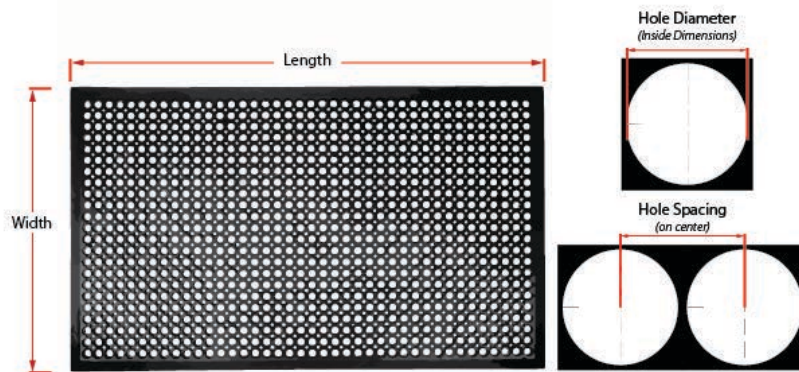

▶ Mat Cart

Model No.	Size W-H-D	Weight Capacity	Ship Lbs.	List Price
All Welded				
99360	41½" x 40" x 27½"	500 lbs.	40	\$ 1,353
Four 5" plate type swivel casters; two with brake.				
Knocked-Down				
51087	24" x 45¼" x 36"	500 lbs.	37	\$ 1,376
Four 5" plate type swivel casters with brake.				

- Labor saving mobile mat carts keep mats off of the floor for easy, efficient cleaning.
- Hooks secure perforated mats for storage and cleaning.
- Center horizontal bars hold solid mats. (all welded unit only)
- Open design allows use of waste container. (K.D. model only)
- Ideal for power washing mats on the cart.
- Lifetime Guarantee against rust and corrosion.



99360



51087



Casters

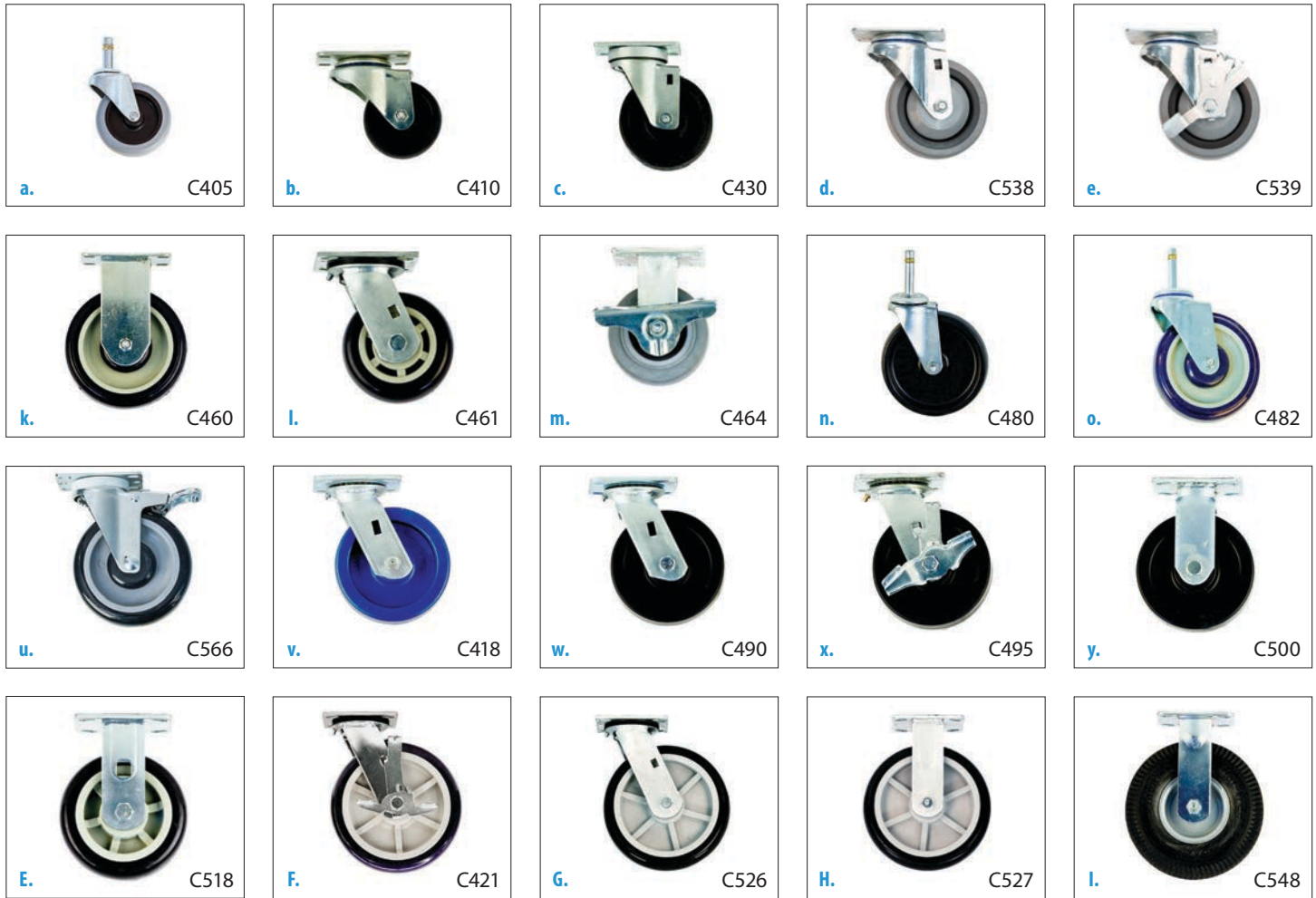



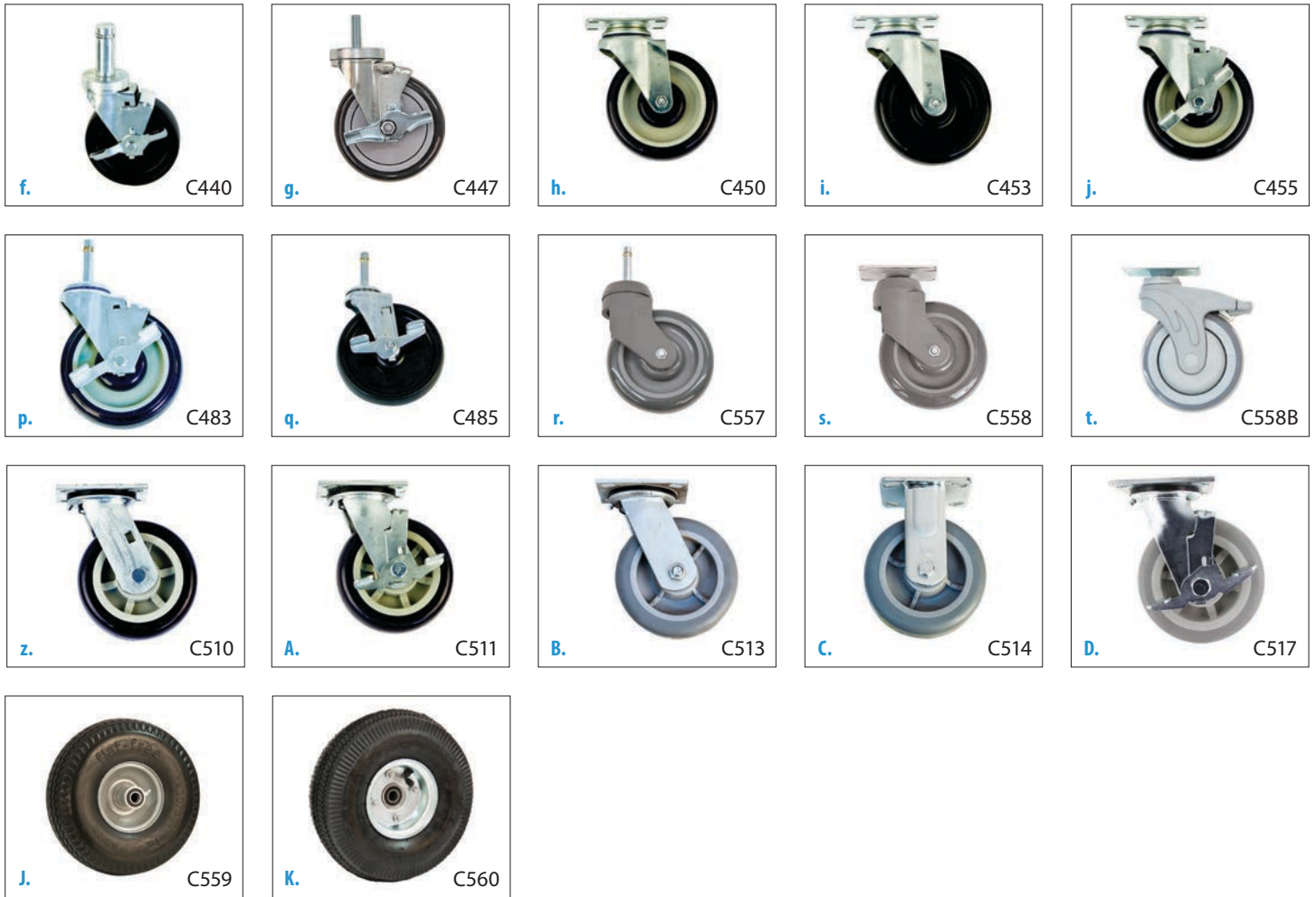





Model No.	Caster Size	Caster Type	Caster Description	Wheel Material	Maximum Temperature	Weight Capacity (lbs.)	Stem Diameter/ Hole Pattern	List Price
a. C405	3" x 7/16"	Stem	Swivel	Polyurethane Wheel	180°	125	7/16" Stem	\$ 40
b. C410	3" x 13/8"	Plate	Swivel	Polyolefin Wheel	140°	200	13/4" x 3"	\$ 63
c. C430	4" x 1 1/2"	Plate	Swivel	Hi-temp Wheel (above 400°)	550° intermittent 425° continuous	400	13/4" x 3"	\$ 89
d. C538	4" x 1 1/4"	Plate	Swivel	TPR Wheel,	140°	250	13/4" x 3"	\$ 78
e. C539	4" x 1 1/4"	Plate	Swivel w/ brake	TPR Wheel	140°	250	13/4" x 3"	\$ 128
f. C440	5" x 1 3/8"	Stem	Swivel w/ brake	Polyolefin Wheel	140°	300	1" Stem	\$ 77
g. C447	5" x 1 3/8"	Stem	Swivel w/ brake	Polyolefin Wheel	140°	200	1/2" Stem	\$ 104
h. C450	5" x 1 3/8"	Plate	Swivel	Polyolefin Hub, Polyurethane Tread	180°	250	13/4" x 3"	\$ 71
i. C453	5" x 1 1/4"	Plate	Swivel	Polyolefin Hub, Polyurethane Tread	140°	225	13/4" x 3"	\$ 65
j. C455	5" x 1 3/8"	Plate	Swivel w/ brake	Polyolefin Hub, Polyurethane Tread	180°	250	13/4" x 3"	\$ 85
k. C460	5" x 1 3/8"	Plate	Rigid	Polyolefin Hub, Polyurethane Tread	180°	250	13/4" x 3"	\$ 77
l. C461	5" x 2"	Plate	Swivel	Polyolefin Hub, Polyurethane Tread	140°	800	3" x 3"	\$ 130
m. C464	5" x 2"	Plate	Rigid w/ brake	Polyolefin Hub, TPR Tread	120°	350	3" x 3"	\$ 143
n. C480	5" x 1"	Stem	Swivel	Polyolefin Wheel	130°	135	7/16" Stem	\$ 54
o. C482	5" x 1 3/8"	Stem	Swivel	Polyolefin Hub, Polyurethane Tread	180°	250	7/16" Stem	\$ 69
p. C483	5" x 1 3/8"	Stem	Swivel w/ brake	Polyolefin Hub, Polyurethane Tread	180°	250	7/16" Stem	\$ 77
q. C485	5" x 1"	Stem	Swivel w/ brake	Polyolefin Wheel	130°	135	7/16" Stem	\$ 60
r. C557	5" x 1 1/4"	Stem	Swivel	TPR Wheel, Synthetic Rig	150°	250	7/16" Stem	\$ 108
s. C558	5" x 1 1/4"	Plate	Swivel	TPR Wheel, Synthetic Rig	150°	250	13/4" x 3"	\$ 130
t. C558B	5" x 1 1/4"	Plate	Swivel w/brake	TPR Wheel, Synthetic Rig	150°	250	13/4" x 3"	\$ 152
u. C566	5" x 1 3/8"	Plate	Swivel w/total lock	Polyolefin Hub, Polyurethane Tread	180°	350	13/4" x 3"	\$ 94



	Model No.	Caster Size	Caster Type	Caster Description	Wheel Material	Maximum Temperature	Weight Capacity (lbs.)	Stem Diameter/ Hole Pattern	List Price
v.	C418	6" x 2"	Plate	Swivel	K-Urethane Wheel	180°	700	3" x 3"	\$ 256
w.	C490	6" x 2"	Plate	Swivel	Polyolefin Wheel	190°	700	3" x 3"	\$ 144
x.	C495	6" x 2"	Plate	Swivel w/ brake	Polyolefin Wheel	190°	700	3" x 3"	\$ 152
y.	C500	6" x 2"	Plate	Rigid	Polyolefin Wheel	190°	700	3" x 3"	\$ 105
z.	C510	6" x 2"	Plate	Swivel	Polyolefin Hub, Polyurethane Tread	140°	700	3" x 3"	\$ 130
A.	C511	6" x 2"	Plate	Swivel w/ brake	Polyolefin Hub, Polyurethane Tread	140°	700	3" x 3"	\$ 184
B.	C513	6" x 2"	Plate	Swivel	TPR "Softie" A70	150°	800	3" x 3"	\$ 150
C.	C514	6" x 2"	Plate	Rigid	TPR "Softie" A70	150°	800	3" x 3"	\$ 142
D.	C517	6" x 2"	Plate	Swivel w/ brake	TPR "Softie" A70	150°	800	3" x 3"	\$ 166
E.	C518	6" x 2"	Plate	Rigid	Polyolefin Hub, Polyurethane Tread	140°	700	3" x 3"	\$ 108
F.	C421	8" x 2"	Plate	Swivel w/ brake	Polyolefin Hub, Polyurethane Tread	185°	900	3" x 3"	\$ 193
G.	C526	8" x 2"	Plate	Swivel	Polyolefin Hub, Polyurethane Tread	185°	900	3" x 3"	\$ 181
H.	C527	8" x 2"	Plate	Rigid	Polyolefin Hub, Polyurethane Tread	185°	800	3" x 3"	\$ 150
I.	C548	8" x 2"	Plate	Rigid	Metal Hub, Carefree	140°	300	3" x 3"	\$ 276
J.	C559	10" x 3½"	Axle	Flat Free	Steel Hub, Non-scuff Polyurethane	N/A	400	⅝" DIA	\$ 250
K.	C560	10" x 3½"	Axle	Pneumatic	Steel Hub / 4-ply Rubber	N/A	400	⅝" DIA	\$ 172

Product Options & Accessories - Options may not be NSF Certified. Contact the factory.

<p>"B" - Corner Bumpers (4) • Add "B" suffix to the model #. \$ 116</p> <p>Non-marking gray rubber, mounted to the corners of the unit's base. Note: This option adds 2" to the width and depth of the unit. Corner bumpers available on full frame units only. Check specific model options for availability.</p>	
<p>"CL" - Caster Locks (2)</p> <p>(A) 5" stem caster 7/16" dia. — Add "CL" suffix to the model #. \$ 14 (B) 5" platform caster — Add "CL" suffix to the model #. \$ 16 (C) 6" platform caster — Add "CL" suffix to the model #. \$ 47 (D) 6" platform K-Urethane caster — Add "CL" suffix to the model #. \$ 79 (E) 8" platform caster — Add "CL" suffix to the model #. \$ 133</p>	
<p>"E" - Solid Base • Add "E" suffix to the model #. \$ 260</p> <p>Solid aluminum sheet welded to the top of the unit's base. MUST be factory installed.</p>	
<p>"M6" - Caster Upgrade • Add "M6" suffix to the model #. \$ 430</p> <p>Upgrade from 5" platform type casters to 6" platform type casters. May change height of racks.</p> <p>"MD" - Medical Caster Upgrade • Add "MD" suffix to the model #. \$ 343</p> <p>Upgrade to 5" medical grade casters. Caster Locks are unavailable for some models. *** Caster upgrades are not available for all products. ***</p>	
<p>"PB" - Perimeter Bumpers • Add "PB" suffix to the model #. \$ 341</p> <p>Non-marking gray rubber strip, usually affixed around the unit's base. Note: This option adds 2" to the width and depth of the unit. MUST be factory installed.</p>	
<p>"PP" - Prison Package</p> <p>(A) Tamper Resistant Screws — Add "PP" suffix to the model #. \$ 88 (B) Tamper Resistant Screws, Welded Hinges, Extra Interior Bracing (reduces pan capacity), 6" Caster Upgrade, Padlock Holes in Door — Add "PP" suffix to the model #. \$ 442 (C) Tamper Resistant Screws / All Welded Handle — Add "PP" suffix to the model #. \$ 186</p>	
<p>"PS" - Pan Stop • Add "PS" suffix to the model #. \$ 71</p> <p>Aluminum strap welded to the rear of the unit — Prevents pans from pushing off the back of the unit. MUST be factory installed.</p>	
<p>"VB" - Vertical Bumpers (4) • Add "VB" suffix to the model #. \$ 198</p> <p>Non-marking black rubber strips, usually 8" long, mounted near the bottom of the unit's uprights. Note: This option adds 1" to the width and depth of the unit.</p>	
<p>#1359 - Rack Cover (Clear, 12 mil.) • 23"W x 64"H x 28"D \$ 325</p> <p>Universal End-Load/Side-Load Rack Cover. Clear for product visibility. Three full zippers.</p>	

Ordering Information

Prices: Prices in this Price List are effective January 1, 2024. For additional product information please visit our website at www.NewAgeIndustrial.com, AutoQuotes®, or contact the factory. Specifications and prices are subject to change without prior notice.

Quotations: Quotations are valid for 15 days from the date of the quotation. Changes in raw materials or economic factors are beyond our control. New Age reserves the right to increase prices with 30 days notice or at the time of the order confirmation.

Cancellations: Cancelled orders within two weeks of scheduled shipment are subject to a cancellation charge of 25% of the total purchase order.

Terms of Payment: Payment in full 30 days after shipment or C.O.D. at the discretion of New Age Industrial's Credit Department. If you are a new customer and are not listed in Dun & Bradstreet, please give us the name and address of three credit references and your bank, unless you prefer C.O.D. terms. We also accept Visa, Master Card, and American Express payments.

Past due accounts are subject to 1.5% interest per month.

Damaged or Lost Goods: It is the responsibility of the consignee's receiving agent to inspect equipment upon delivery. If you see your shipment is incomplete or damaged when you receive it make a notation on the freight bill — If the freight company will not allow you to do so, refuse shipment. If the damage is concealed, you must notify New Age within 15 days (including the day of delivery plus weekends and holidays). New Age will handle all claim paperwork for the customer.

Returns: Returned merchandise must be pre-approved with a RMA number assigned by New Age and noted on both the shipping label and bill of lading. Merchandise is to be returned with transportation charges prepaid and is subject to a 20% handling and inspection charge. **New Age reserves the right to refuse the return of any piece of equipment.**

Acceptance: Possession of Price List does not constitute an offer to sell. Orders are subject to acceptance by New Age Industrial.

Custom Equipment: All equipment not listed in this Price List shall be considered "custom". **POSITIVELY NO RETURNS will be accepted on "custom" built equipment.**

NSF: New Age Industrial Corp., Inc. food service products are manufactured and designed with high sanitary standards and most are listed by NSF International. For specific items, please refer to the latest NSF food service listing.



Safety: For the most current safety information, see www.NewAgeIndustrial.com or call 800-255-0104.

Guarantees

New Age Industrial Corporation, Inc. guarantees that the products listed in their most recent price list (casters, wheels, lugs, tubs, lids, covers, fastening devices and other accessories excluded) will not rust or corrode for the period of time the original purchaser owns it, provided the products are used within the listed restrictions.



The Lifetime Series and "Adjust-A-Shelf" Shelving products are guaranteed for the LIFETIME of the original purchaser. They will be free from defects in material and workmanship and will not rust or corrode if used within the listed restrictions.



New Age Industrial Corporation, Inc. guarantees the original owner that its products will be free from defects in material and workmanship (when properly installed) for FIVE YEARS, provided the product has been used within the listed restrictions.



New Age Industrial Corporation, Inc. guarantees the original owner that its products will be free from defects in material and workmanship (when properly installed) for ONE YEAR, provided the product has been used within the listed restrictions.

Restrictions

1. Your New Age product must be used solely for its intended purpose. Abuse of, misuse of, changes to, alteration of, or improper maintenance of original equipment shall void any warranty.
2. Your New Age product must not be loaded beyond the product's published uniformly distributed static load limit (capacity).
3. Your New Age product must be cleaned on a periodic basis every three to four weeks or be cleaned within accepted industry standards, following the generally accepted cleansing agent's instructions.
4. New Age shall not be liable for incidental, special, indirect, or consequential damages arising or resulting from misuse, use, inability to use, or from product defects or other tort.

If requested, the damaged product will be returned to New Age at the owner's expense for inspection and approval.

New Age Industrial Corporation, Inc.
16788 US Hwy 36 • PO Box 520
Norton, KS 67654

Index

0116.....	43	1125A.....	44	1277.....	61	1375W.....	52	1854SB.....	41	21548ES24P.....	54
0117.....	34,37,38	1126.....	44	1279.....	61	1376.....	52	1854TB.....	40	21548ES30P.....	54
0118.....	33,34	1126A.....	44	1288.....	47	1377.....	52	1860HD.....	39	21548ES36P.....	54
0119.....	44	1127.....	44	1289.....	47	1378.....	52	1860SB.....	41	21824ES24P.....	54
0300.....	60	1127A.....	44	1290.....	14	1379.....	52	1860TB.....	40	21824ES30P.....	54
0307.....	27,58	1137.....	16	1290A.....	14	1380.....	52	1866HD.....	39	21824ES36P.....	54
0350.....	17	1139.....	16	1290WDW.....	13	1381.....	52	1866TB.....	40	21830ES24P.....	54
0351.....	17	1151.....	67	1291.....	14	1382.....	52	1872HD.....	39	21830ES30P.....	54
0360.....	60	1152.....	67	1292.....	14	1383.....	52	1872SB.....	41	21830ES36P.....	54
0360L.....	60	1161.....	64	1293.....	14	1384.....	52	1872TB.....	40	21836ES24P.....	54
0361.....	61	1162.....	64	1296.....	14	1407.....	58	1872UB.....	47	21836ES30P.....	54
0363.....	60	1163.....	64	12P.....	43	1408.....	57	2001.....	36	21836ES36P.....	54
0363L.....	60	1164.....	64	1303GGS.....	54	1410.....	57	2002.....	36	21842ES24P.....	54
0381.....	60	1171.....	27	1303GSC.....	54	1415.....	55	2003.....	36	21842ES30P.....	54
0381L.....	60	1172.....	27	1303GSCU.....	54	1416.....	55	2004.....	36	21842ES36P.....	54
0382.....	60	1174.....	27,35	1303GGSU.....	54	1420.....	55	2005.....	36	21848ES24P.....	54
0382L.....	60	1176A.....	28	13048GS.....	54	1430.....	67	2006.....	36	21848ES30P.....	54
0814.....	60	1179A.....	28	13048GSC.....	54	1431.....	67	2007.....	36	21848ES36P.....	54
0816.....	60	1181.....	31	13048GSCU.....	54	1440.....	32	2008.....	36	22024ES24P.....	54
0818.....	60	1182.....	31	13048GSU.....	54	1450.....	35	2009.....	36	22024ES30P.....	54
0820.....	60	1183.....	66	1305.....	8	1451.....	25	2010.....	36	22024ES36P.....	54
1021.....	37	1184.....	66	1306.....	8	1452.....	25	2012.....	36	22030ES24P.....	54
1021TB.....	38	1187.....	31	13060GS.....	54	1455.....	25	2013.....	36	22030ES30P.....	54
1022.....	37	1188.....	31	13060GSC.....	54	1461.....	1	2014.....	36	22030ES36P.....	54
1022TB.....	38	1192.....	30	13060GSCU.....	54	1461S.....	1	2015.....	36	22036ES24P.....	54
1023.....	37	1193.....	30	13060GSU.....	54	1481.....	5	2016.....	36	22036ES30P.....	54
1023TB.....	38	1194.....	30	13072GS.....	54	1482.....	5	2017.....	36	22036ES36P.....	54
1024.....	37	1195.....	32	13072GSC.....	54	1484.....	5	2018.....	36	22042ES24P.....	54
1024TB.....	38	1196.....	32	13072GSCU.....	54	1486.....	5	2019.....	36	22042ES30P.....	54
1025.....	37	1199.....	27,30-32	13072GSU.....	54	1490.....	55	2020.....	36	22042ES36P.....	54
1025TB.....	38	1200.....	35	1311.....	1	1501.....	36	2021.....	36	22048ES24P.....	54
1026.....	37	1201.....	35	1312.....	1	1505.....	6	2022.....	36	22048ES30P.....	54
1026TB.....	38	1202.....	35	1313.....	1	1507.....	6	2026.....	36	22048ES36P.....	54
1027.....	37	1203.....	35	1314.....	1	1509.....	6	2027.....	36	2430HD.....	39
1027TB.....	38	1204.....	35	1315.....	58	1530HD.....	39	2028.....	36	2430SB.....	41
1028.....	37	1205.....	35	1316.....	58	1530S.....	42	2029.....	36	2430TB.....	40
1028TB.....	38	1206.....	35	1321.....	1	1530SB.....	41	2030HD.....	39	2436HD.....	39
1030.....	37	1207.....	35	1322.....	1	1530TB.....	40	2030S.....	42	2436SB.....	41
1030TB.....	38	1208.....	35	1330.....	1	1536HD.....	39	2030SB.....	41	2436TB.....	40
1031.....	37	120T.....	52	1330S.....	1	1536S.....	42	2030TB.....	40	2436UB.....	43
1031TB.....	38	120W.....	52	1330U.....	7	1536SB.....	41	2031.....	36	2442HD.....	39
1041.....	37	1210.....	19	1330Z.....	7	1536TB.....	40	2032.....	36	2442SB.....	41
1041TB.....	38	1211.....	35	1331.....	1	1542HD.....	39	2033.....	36	2442TB.....	40
1042.....	37	1212.....	35	1331S.....	1	1542S.....	42	2036HD.....	39	2442UB.....	43
1042TB.....	38	1213.....	35	1331U.....	7	1542SB.....	41	2036S.....	42	2448HD.....	39
1043.....	37	1214.....	35	1331Z.....	7	1542TB.....	40	2036SB.....	41	2448SB.....	41
1043TB.....	38	1215.....	19	1332.....	1	1548HD.....	39	2036TB.....	40	2448TB.....	40
1044.....	37	1225.....	33	1332S.....	1	1548S.....	42	2036UB.....	43	2448UB.....	43
1044TB.....	38	1226.....	33	1332Z.....	7	1548SB.....	41	2042HD.....	39	2454HD.....	39
1045.....	37	1226NT.....	33	1333.....	1	1548TB.....	40	2042S.....	42	2454SB.....	41
1045TB.....	38	1227.....	33	1333S.....	1	1554HD.....	39	2042SB.....	41	2454TB.....	40
1046.....	37	1235.....	33	1333Z.....	7	1554SB.....	41	2042TB.....	40	2460HD.....	39
1046TB.....	38	1236.....	33	1334.....	1	1554TB.....	40	2042UB.....	43	2460SB.....	41
1047.....	37	1236NT.....	33	1334S.....	1	1560HD.....	39	2048HD.....	39	2460TB.....	40
1047TB.....	38	1237.....	33	1335.....	3	1560S.....	41	2048S.....	42	2460UB.....	43
1048.....	37	12436GS.....	54	1336.....	3	1560TB.....	40	2048SB.....	41	2466HD.....	39
1048TB.....	38	12436GSC.....	54	1337.....	3	1566HD.....	39	2048TB.....	40	2466SB.....	41
1050.....	37	12436GSCU.....	54	1338.....	3	1566TB.....	40	2048UB.....	43	2466TB.....	40
1050TB.....	38	12436GSU.....	54	1340.....	63	1572HD.....	39	2051.....	36	2472HD.....	39
1051.....	37	12448GS.....	54	1343.....	63	1572TB.....	40	2052.....	36	2472SB.....	41
1051TB.....	38	12448GSC.....	54	1345.....	63	1610.....	9	2054.....	36	2472TB.....	40
1061.....	37	12448GSCU.....	54	1346.....	63	1612.....	9	2054HD.....	39	2496HD.....	39
1061TB.....	38	12448GSU.....	54	1347.....	63	1620.....	31	2054SB.....	41	24ESA29.....	53
1062.....	37	12460GS.....	54	1348.....	63	1622.....	31	2054TB.....	40	24ES529.....	53
1062TB.....	38	12460GSC.....	54	1349.....	63	1630.....	27	2060HD.....	39	24P36KD.....	51
1063.....	37	12460GSCU.....	54	1350.....	63	1631.....	27	2060SB.....	41	24P48KD.....	51
1063TB.....	38	12460GSU.....	54	1354.....	64	1635.....	8	2060TB.....	40	24P60KD.....	51
1064.....	37	12472GS.....	54	1355.....	64	1637.....	8	2060UB.....	43	24P72KD.....	51
1064TB.....	38	12472GSC.....	54	1355M.....	64	1640.....	8	2062.....	36	24P84KD.....	51
1065.....	37	12472GSCU.....	54	1356.....	62	1642.....	8	2064.....	36	24P96KD.....	51
1065TB.....	38	12472GSU.....	54	1356M.....	62	1650.....	9	2066HD.....	39	24PBS36KD.....	51
1066.....	37	1250.....	33	1357.....	62	1655.....	9	2066SB.....	41	24PBS48KD.....	51
1066TB.....	38	1250CK.....	33	1358.....	62	1830HD.....	39	2066TB.....	40	24PBS60KD.....	51
1067.....	37	1251.....	33	1359.....	2,71	1830S.....	42	2072HD.....	39	24PBS72KD.....	51
1067TB.....	38	1254.....	33	1361.....	1	1830SB.....	41	2072SB.....	41	24PBS84KD.....	51
1068.....	37	1255.....	33	1371T.....	52	1830TB.....	40	2072TB.....	40	24PBS96KD.....	51
1068TB.....	38	1256.....	33	1371W.....	52	1836HD.....	39	2096HD.....	39	24SS36KD.....	51
1070.....	37	1256CK.....	33	1372W.....	52	1836S.....	42	21524ES24P.....	54	24SS48KD.....	51
1070TB.....	38	1257.....	33	1372Z.....	52	1836SB.....	41	21524ES30P.....	54	24SS60KD.....	51
1071.....	37	1261.....	59	1373CL.....	52	1836TB.....	40	21524ES36P.....	54	24SS72KD.....	51
1071TB.....	38	1262.....	59	1373CT.....	52	1842HD.....	39	21530ES24P.....	54	24SS84KD.....	51
1121.....	44	1263.....	59	1373T.....	52	1842S.....	42	21530ES30P.....	54	24SS96KD.....	51
1121PR.....	44	1264.....	59	1373W.....	52	1842SB.....	41	21530ES36P.....	54	24SSB36KD.....	51
1122.....	44	1265.....	59	1374CL.....	52	1842TB.....	40	21536ES24P.....	54	24SSB48KD.....	51
1122PR.....	44	1265H.....	59	1374CT.....	52	1848HD.....	39	21536ES30P.....	54	24SSB60KD.....	51
1123.....	44	1266.....	59	1374T.....	52	1848S.....	42	21536ES36P.....	54	24SSB72KD.....	51
1123PR.....	44	1266H.....	59	1374W.....	52	1848SB.....	41	21542ES24P.....	54	24SSB84KD.....	51
1124.....	44	1267.....	59	1375.....	52	1848TB.....	40	21542ES30P.....	54	24SSB96KD.....	51
1125.....	44	1276.....	61	1375T.....	52	1854HD.....	39	21542ES36P.....	54	24US36KD.....	51

24US48KD.....	51	4338.....	12	6015.....	35	96704.....	23	99456.....	22	NS834.....	4
24US60KD.....	51	4339.....	11	6016.....	35	96705.....	23	99457.....	22	NS834A.....	4
24US72KD.....	51	4340.....	11	6017.....	35	96706.....	23	99521.....	60	NS885.....	43
24US84KD.....	51	45106.....	1	6018.....	35	96707.....	23	99551.....	50	NS893.....	4
24US96KD.....	51	45256.....	1	6019.....	35	96708.....	23	99653.....	52	NS926.....	27
2501.....	45	4635.....	12	60328.....	65	96709.....	23	99654.....	52	NS933.....	47
2502.....	45	4637.....	12	60329.....	65	96710.....	23	99738.....	21	NS943.....	44
2503.....	45	4640.....	11	60330.....	65	96711.....	23	99821.....	52	NS947KD.....	18
2505.....	45	4642.....	11	60P.....	43	96856.....	65	99822.....	52	NS968.....	27
2511.....	45	48P.....	43	6259.....	34	97055.....	30	99823.....	52	P2448.....	19
2512.....	45	50112.....	30	6262.....	59	97073.....	9	99824.....	52	P2460.....	19
2513.....	45	50313.....	43	6263.....	59	97102.....	44	99825.....	52	PC432.....	43
2515.....	45	50314.....	43	6265.....	59	97126.....	57	99826.....	52	PM2448.....	19
2521.....	45	50315.....	43	6266.....	59	97142.....	28	99866.....	7	PM2460.....	19
2522.....	45	50316.....	43	6300.....	2	97177.....	24	99936.....	29	PT2436P6.....	66
2523.....	45	50723.....	47	6301.....	2	97178.....	24	99970.....	22	PT2436S6.....	66
2525.....	45	50875.....	22	6303.....	2	97179.....	24	BDT18566.....	66	PT2448P6.....	66
2531.....	45	51019.....	47	6330.....	2	97180.....	24	BDT18568.....	66	PT2448S6.....	66
2532.....	45	51020.....	47	6331.....	2	97205.....	59	C1836HD.....	42	PT3048P6.....	66
2533.....	45	51021.....	47	6333.....	2	97243.....	15	C1836TB.....	42	PT3048S6.....	66
2535.....	45	51022.....	47	6345.....	63	97253.....	59	C1848HD.....	42	PT3060P6.....	66
2541.....	45	51023.....	47	6347.....	63	97285.....	44	C1848TB.....	42	PT3060S6.....	66
2542.....	45	51024.....	47	6348.....	63	97286.....	44	C1860HD.....	42	PT3660P6.....	66
2543.....	45	51025.....	47	6354.....	64	97287.....	44	C1860TB.....	42	PT3660S6.....	66
2545.....	45	51026.....	47	68P.....	43	97294.....	34	C2436HD.....	42	PT3672P6.....	66
2551.....	45	51027.....	47	72P.....	43	97294CK.....	34	C2436TB.....	42	PT3672S6.....	66
2552.....	45	51087.....	68	7331.....	2	97379.....	7	C2448HD.....	42	RGY16825.....	61
2553.....	45	51101.....	35	76P.....	43	97621.....	50	C2448TB.....	42		
2555.....	45	51102.....	35	84P.....	43	97718.....	15	C2460HD.....	42		
2561.....	45	51103.....	35	999.....	52-53	97720.....	22	C2460TB.....	42		
2563.....	45	51107.....	7	92052.....	5	97721.....	22	C2472HD.....	42		
2565.....	45	51169.....	47	92093.....	44	97722.....	22	C2472TB.....	42		
2571.....	45	51170.....	47	92094.....	44	97729.....	9	C405.....	69-70		
2573.....	45	51171.....	47	92096.....	1	97743.....	6	C410.....	69-70		
2575.....	45	51172.....	47	93020KD.....	18	97744.....	6	C418.....	69-70		
2581.....	45	51173.....	47	93037.....	28	97745.....	6	C421.....	69-70		
2582.....	45	51174.....	47	93189.....	30	97746.....	15	C430.....	69-70		
2583.....	45	51181.....	47	94029.....	47	97747.....	15	C440.....	43, 69-70		
2585.....	45	51182.....	47	94030.....	47	97753.....	46	C447.....	69-70		
3030HD.....	39	51233.....	45	94031.....	47	97754.....	46	C450.....	69-70		
3036HD.....	39	51268.....	48	94136.....	44	97755.....	46	C453.....	69-70		
3048HD.....	39	51270.....	48	94249.....	44	97769.....	24	C455.....	69-70		
30P36KD.....	51	51271.....	48	94273.....	47	97846.....	50	C460.....	69-70		
30P48KD.....	51	51273.....	48	94274.....	47	97873.....	53	C461.....	69-70		
30P60KD.....	51	51274.....	48	94275.....	47	97874.....	53	C464.....	69-70		
30P72KD.....	51	51276.....	48	95048.....	4	97875.....	53	C480.....	69-70		
30P84KD.....	51	51280.....	47	95136.....	58	97876.....	53	C482.....	69-70		
30P96KD.....	51	51298.....	47	95141.....	14	97877.....	53	C483.....	69-70		
30PBS36KD.....	51	51299.....	47	95219.....	30	97878.....	53	C485.....	69-70		
30PBS48KD.....	51	51300.....	47	95241.....	65	97879.....	53	C490.....	69-70		
30PBS60KD.....	51	51305.....	48	95333.....	23	9787C.....	53	C495.....	69-70		
30PBS72KD.....	51	51328.....	48	95370.....	65	9789C.....	53	C500.....	69-70		
30PBS84KD.....	51	51412.....	48	95403.....	46	9790C.....	53	C510.....	69-70		
30PBS96KD.....	51	51619.....	60	95404.....	46	97880.....	53	C511.....	69-70		
30SS36KD.....	51	51620.....	60	95405.....	46	97942.....	25	C513.....	69-70		
30SS48KD.....	51	51621.....	60	95410.....	47	98000.....	21	C514.....	69-70		
30SS60KD.....	51	51622.....	60	95413.....	23	98001.....	21	C517.....	69-70		
30S572KD.....	51	51753.....	48	95433.....	3	98037.....	48	C518.....	69-70		
30SS84KD.....	51	51949.....	29	95435.....	48	98040.....	32	C526.....	69-70		
30SS96KD.....	51	51956.....	48	95436.....	48	98063.....	16	C527.....	69-70		
30SSB36KD.....	51	52038.....	4	95437.....	48	98138.....	22	C538.....	69-70		
30SSB48KD.....	51	52049.....	48	95549.....	48	98142.....	32	C539.....	69-70		
30SSB60KD.....	51	52050.....	48	95456.....	35	98144.....	53	C548.....	69-70		
30SSB72KD.....	51	52064.....	48	95631.....	46	98167.....	50	C557.....	69-70		
30SSB84KD.....	51	52199.....	6	95632.....	46	98179.....	21	C557B.....	69-70		
30SSB96KD.....	51	52264.....	48	95633.....	46	98181.....	25	C558.....	69-70		
30US36KD.....	51	52284.....	48	95634.....	44	98182.....	25	C559.....	69-70		
30US48KD.....	51	52352.....	48	95636.....	29	98183.....	25	C560.....	69-70		
30US60KD.....	51	52354.....	48	95661.....	56	98195.....	30	C566.....	69-70		
30US72KD.....	51	52355.....	48	95667.....	20	98213.....	32	NS345.....	28		
30US84KD.....	51	52437.....	48	95681.....	4	98272.....	32	NS475.....	47		
30US96KD.....	51	52446.....	48	95762.....	67	98301.....	32	NS496.....	43		
31842TT7.....	47	52677.....	68	95762RS.....	67	98716.....	29	NS557.....	56		
34P.....	43	52711.....	18	95864.....	3	98736.....	29	NS557A.....	56		
4004.....	36	52861.....	26	95883.....	44	98737.....	29	NS590A.....	22		
4005.....	36	52918.....	26	95958.....	1	98951.....	47	NS596A.....	22		
4006.....	36	52919.....	26	96004.....	17	98953.....	47	NS599A.....	22		
4008.....	36	52924.....	28	96005.....	17	98998.....	30	NS600A.....	22		
4009.....	36	53082.....	28	96055.....	67	99217.....	21	NS603A.....	22		
4010.....	36	53338.....	26	96055RS.....	67	99251.....	61	NS621KD.....	18		
4027.....	36	53757.....	26	96058.....	4,8	99271.....	60	NS648.....	5		
4065.....	36	54P.....	43	96087.....	23	99272.....	60	NS675.....	44		
42068.....	9	6004.....	35	96090.....	23	99273.....	60	NS675A.....	44		
42078.....	15	6005.....	35	96134BH.....	56	99274.....	60	NS745.....	32		
4330.....	10	6006.....	35	96328.....	14	99304.....	32,59	NS753.....	44		
4331.....	10	6008.....	35	96492.....	48	99309.....	22	NS765.....	55		
4332.....	10	6009.....	35	96617.....	46	99310.....	22	NS793.....	44		
4333.....	10	6010.....	35	96618.....	46	99360.....	68	NS832.....	4		
4337.....	12	6014.....	35	96619.....	46	99381.....	34	NS833.....	4		

Options:

B.....	2,71
B.....	66
C.....	54
CL (A).....	2,71
CL (B).....	2,71
CL (C).....	71
CL (D).....	71
CL (E).....	71
CW.....	21
DL.....	14-15
E.....	2,71
HD6.....	35
KU.....	10-11
MS.....	37-38
M6.....	37-38
M6.....	2,71
MD.....	2,71
PB.....	2,71
PP "A".....	2,71
PP "B".....	14,71
PP "C".....	71
PS.....	2,71
R.....	65
RD.....	14
SW.....	35
US.....	53
VB.....	2,71
XH.....	49
DSD.....	49
SSD.....	49
8.....	65
1359.....	2,71
36".....	54
48".....	54
60".....	54
72".....	54

Get Featured!



Send Us Your Photos, Reels, Posts & Videos!

Join our social community and stay updated with our latest promos, tips and more.

<https://www.NewAgeIndustrial.com/FeatureMyPhoto>

Facebook



YouTube



LinkedIn



Instagram

