

DWG54514 - AMR Picking Cart

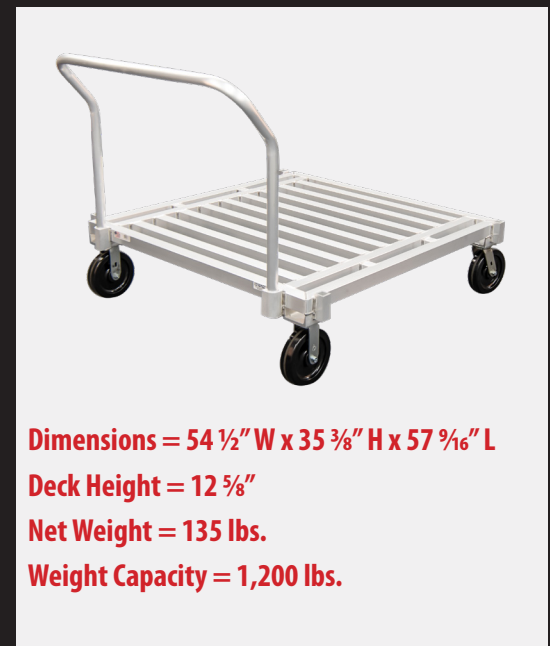

Combine your AMR with our detachable aluminum Picking Carts for seamless utilization of both workers and robots; Allowing product to be queued up without having any AMRs present.

Streamline order picking and fulfillment processes, improving efficiency and overall employee health and safety.



Dimensions = 54 1/2" W x 35 3/8" H x 57 9/16" L

Deck Height = 12 5/8"

Net Weight = 135 lbs.

Weight Capacity = 1,200 lbs.

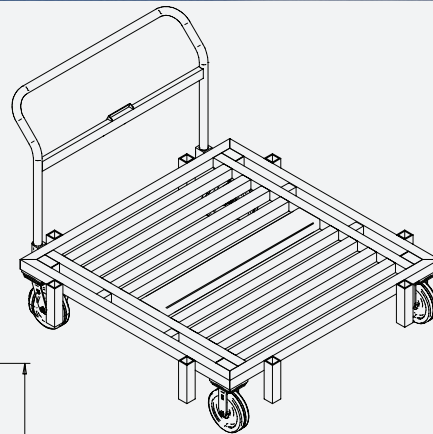

APPROX. WEIGHT: 135 LBS.

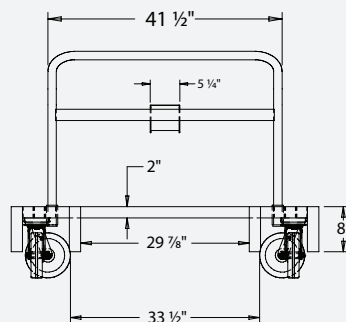
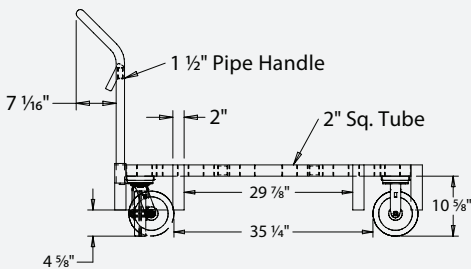
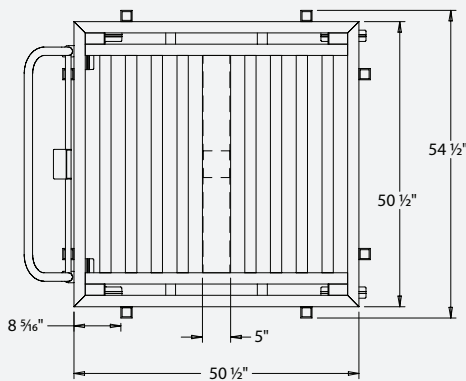

Design allows for effortless, two-sided picking for faster e-commerce order fulfillment.

Used in:

- E-Commerce
- Warehouses
- Retail Service Centers

NEWAGE
INDUSTRIAL
NEWAGE

NewAgeIndustrial.com | Made in the USA