

# 53960 - Raised Picking Pallet



# PICK SAFETY FIRST.

Worker safety is always our top priority. This pallet checks all of the boxes for worker safety and efficiency.

## Reach New Heights of Efficiency - with Raised Picking Pallets.

The **Raised Picking Pallet** design puts products within easy reach, minimizing wasted movement and bending; Maximizing efficiency and safety in your warehouse. This translates to faster picking times and increased order fulfillment rates.



Ergonomic Picking Height



Precise Deck Height and Toe Kick

**NEWAGE  
INDUSTRIAL  
NEWAGE**

NewAgeIndustrial.com | Made in the USA



99664 Order Picking Cage

## Aluminum Reduces The Overall Weight By 1/3 Compared To Traditional Steel Cages.

New Age **Order Picking Cages** are specially designed to improve efficiency when used with an order selector in distribution centers. The cages are constructed from lightweight aluminum, which reduces their weight by one-third when compared to traditional steel cages. The shelves of the cage are easy to remove and adjust, which makes them suitable for companies that offer a wide range of products in different sizes.

**ORDER PICKING CAGES**



**Requesting a custom item is easy!**

Contact our in-house design team for a free quote.

**NEW AGE INDUSTRIAL NEW AGE**

NewAgeIndustrial.com | Made in the USA

### ✓ **Lightweight, Durable Aluminum Construction:**

Manufactured from high-quality aluminum, these platforms are built to withstand the rigors of everyday warehouse use.

### ✓ **Reinforced & Built to Last:**

A sturdy welded aluminum frame and full perimeter rubber bumper reinforced with 1/8" x 1/2" steel ensure long-lasting performance.

### ✓ **Effortless Access:**

The raised platform design puts products within easy reach, minimizing wasted movement and bending. This translates to faster picking times and increased order fulfillment rates.

### ✓ **Secure Attachment:**

The platforms securely attach to your order picker cages using replaceable 2" x 4" wood clamp blocks, ensuring a stable and comfortable work environment at any height.

### ✓ **Easy to Maneuver:**

Equipped with five (5) heavy-duty plate type casters, four outside swivel and one center rigid, spring-loaded for ultimate mobility.

### ✓ **Heavy Duty Weight Capacity:**

Safely transport heavy loads with a total weight capacity of 1,200 lbs.

### ✓ **Strong Product Guarantees:**

Backed by a One-Year Guarantee on materials and workmanship and a Lifetime Guarantee against rust and corrosion to provide peace of mind for your investment.

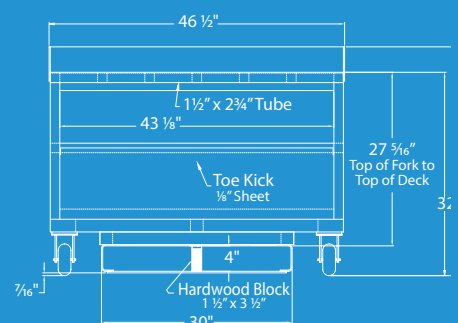
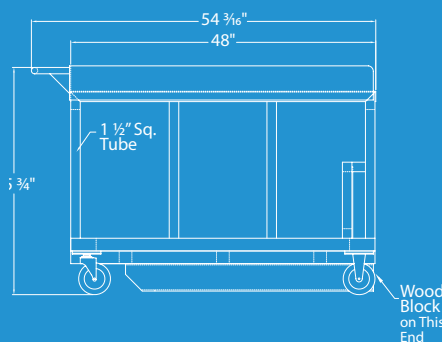
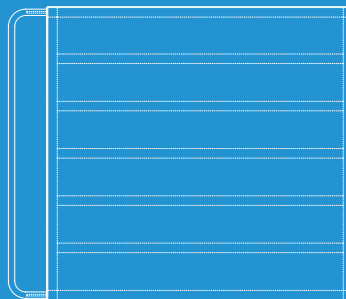

**53960**  
**Raised Picking Pallet**

