

# AS/RS Lightweight Pallet DWG54552

## REDUCES

- ✓ Product Damage
- ✓ Maintenance Cost
- ✓ Shipping Cost



## Increase your productivity...

Lightweight aluminum pallets, enhance AS/RS efficiency by reducing energy consumption and structural load, allowing for higher, faster, and more reliable handling. Their consistent weight and dimensions improve uptime by preventing conveyor jams, limiting machinery wear, and ensuring smooth, non-porous interaction with automated grippers and sensors.



*Weights  
37.5 lbs.*

DWG54552

All welded  
construction  
with all seams  
fully sealed.

Dimensions = 40"W x 6"H x 48"L

### LOAD WEIGHTS:

STATIC	15,000 Lbs.
DYNAMIC	2,000 Lbs.
RACKABLE	2,000 Lbs.
ALUMINUM WEIGHT	37.5 Lbs.

**NEWAGE  
INDUSTRIAL  
NEWAGE**

NewAgeIndustrial.com | Made in the USA

# Why Aluminum?

## Longer life, lower maintenance.

New Age Aluminum Pallets are the perfect solution for your shipping, storage, and warehouse needs. Aluminum pallets will not rust, rot, warp, or burn; Giving you a better return on your investment.

### Aluminum

- Can be stored indoors.
- 100% Metal Detectable.
- UV Resistant.
- Fire Resistant.
- Outlasts Wood and Plastic 10 to 1.
- Built to your exact needs.
- Recyclable.
- Hygienic.
- Repairable.

### Wood

- Requires storage outdoors or in a separate facility per NEPA, 1 fire code.
- Invites insect infestation.
- Flammable.
- Requires harsh chemicals to sanitize.
- Splinter and break.
- Not suitable for food manufacturing.
- Requires frequent repair or replacement, on average every 5 trips.
- Absorbs moisture, odors and contaminates.

### Plastic

- Requires storage outdoors or in a separate facility per NEPA, 1 fire code.
- Minimum Quantity = Hundreds.
- Additives weaken pallet.
- Flammable.
- Prone to chipping and contamination.
- Not suitable for transporting loads heavier than 1,500 lbs.
- Their sleek surface makes them slippery and less stable for stacking.
- Hard to repair.

**High-quality pallets enable automated storage and retrieval systems to work at optimum levels of productivity.** If you are working with high-quality pallets consistently, then all of that productivity flows right to your bottom line because you can keep these systems running as fast as they are designed to run without worrying about something getting jammed and stopping your production.

- ✓ **Higher System Speed and Efficiency:** Their lower weight allows AS/RS cranes and conveyors to operate at higher speeds, boosting overall throughput.
- ✓ **Reduced Wear on Equipment:** Because they are lightweight and lack nails or splinters, they reduce friction and damage to conveyor rollers, sensors, and robotic arms, leading to fewer maintenance interruptions.
- ✓ **Improved Accuracy and Consistency:** Uniform dimensions and minimal deflection ensure consistent placement, preventing malfunctions that can be onset by warped plastic or varied wooden pallets.
- ✓ **Optimal Load Stability:** Despite being light, these aluminum pallets are designed for rigidity, reducing product movement, preventing debris, and keeping loads stable.
- ✓ **Increased Storage Capacity:** Reduced pallet weight can allow for higher stacking loads within the constraints of the AS/RS equipment.
- ✓ **Increased Sustainability and Safety:** Made of primary grade aluminum these pallets are recyclable and offer improved hygiene as they are non-porous and easy to clean, which is critical for food/pharma sectors.
- ✓ **Strong Product Guarantees:** Backed by a One-Year Guarantee on materials and workmanship and a Lifetime Guarantee against rust and corrosion to provide peace of mind for your investment.

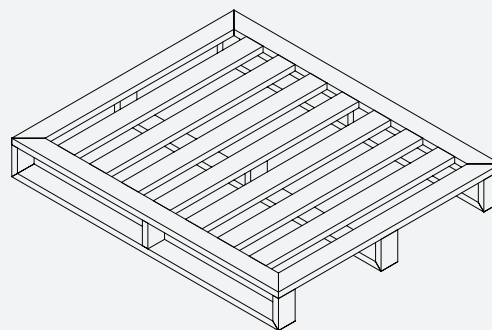

1" x 3" Tube Throughout  
Overall Weight: 37.5 lbs.

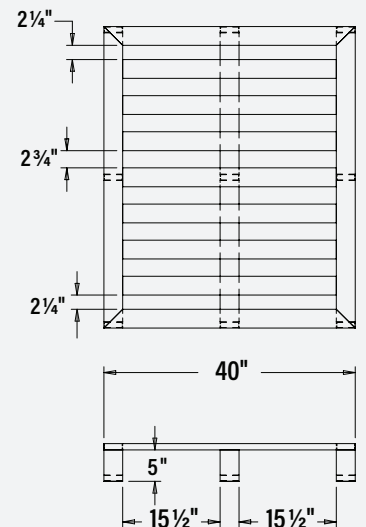
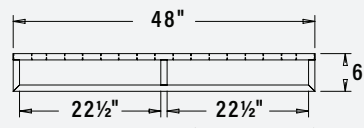

**NEW AGE**  
INDUSTRIAL  
**NEW AGE**

NewAgeIndustrial.com | Made in the USA

