

Project: _____

Item: _____

Quantity: _____

Platform Truck - Folding



The Folding Platform Truck is perfect for moving heavy loads from the back room to the floor area or directly from the truck into a cooler. It is large enough to transport plenty of products to stock a complete area, and this folding delivery truck allows for quick and convenient stocking.

- Handle is 1½" O.D. x .153" wall extruded aluminum tube.
- Cross bars are both horizontal and vertical.
- Integrated solid deck with latch for storing upright.
- Equipped with 6" x 2" plate type TPR casters; two swivel and two rigid.
- One-Year Construction Guarantee against material defects and workmanship.
- Lifetime Guarantee against rust and corrosion.

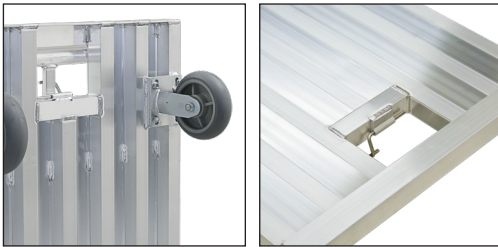

Integrated Solid Deck with Latch For Storing Upright.

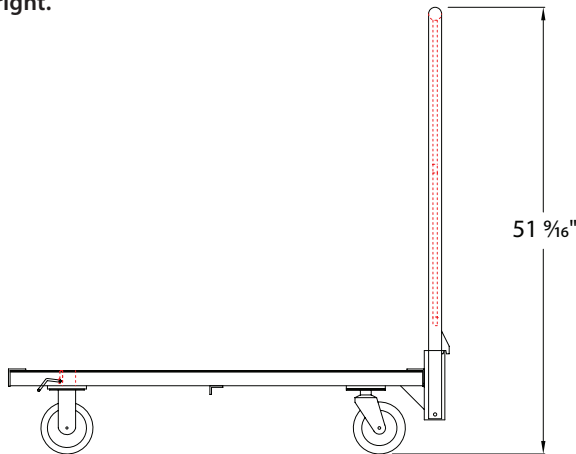

▶ Folding Platform Truck

Model No.	Size W-H-D	Position	Weight Capacity	Net Lbs.	Ship Lbs.
98667	26¼" x 51 ⁵ / ₁₆ " x 48"	Unfolded	800 lbs.	56	68
	6¼" x 12" x 48"	Folded			

Four 6" heavy duty plate casters; two swivel, two rigid.

Options:

- Caster Locks (2)**— Add "CL" suffix to model #.
- Corner Bumpers (4)** — Add "B" suffix to model #.
- Perimeter Bumper (3 Sides)** — Add "PB" suffix to model #.

