

Project: _____

Item: _____

Quantity: _____

Floral Cart NS765

Specifically designed for use the floral industry, this cart is equipped with a 1½" lip that contains the drips and spills common when working with plants and flowers.

With a top shelf at 32" and a width just under 19", this cart provides a convenient worktop that can maneuver through narrow aisles. Equipped with a second shelf to hold more florals or boxes. Corner bumpers protect walls and displays.

The handle and vertical bumpers are standard equipment on this unit.

- Framework is constructed of 1½" x 1½" x .070" wall tubing.
- Shelves are constructed of .080" thick aluminum sheet.
- Equipped with four 5" plate type swivel casters.
- Five-Year Guarantee against material defects and workmanship.
- Lifetime Guarantee against rust and corrosion.



NS765



Spill Containing Shelves

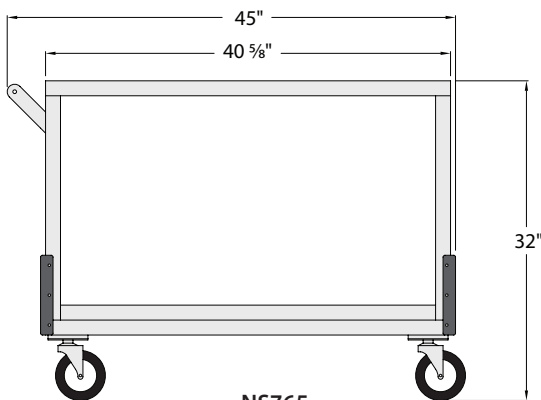
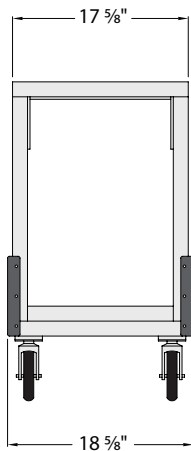

NS765

► Floral Cart

Model No	Size W-H-L	Weight Capacity	Number Of Casters	Top Shelf Height	Shelf Spacing	Ship Lbs.
Solid Top & Bottom Shelf with Handle						
NS765	18 5/8" x 32" x 45"	500 lbs.	4	32"	22 1/2"	43
Four 5" plate type swivel casters.						

Options: ***** FACTORY INSTALLED ONLY*****

- Caster Locks (2)** -- Add "CL" suffix to model #.
- Perimeter Bumper** - Add "PB" suffix to model #.



New Age Industrial Corp., Inc. || NewAgeIndustrial.com || Made in the USA

PO Box 520 • 16788 US Hwy 36 • Norton, Kansas 67654 || Phone: (800) 255-0104 • (785) 877-5121 || Fax: (877)-877-7687 • (785) 877-2616

This information is for general sales and engineering use only. New Age Industrial reserves the right to modify or make changes at any time, without notice, to materials and specifications.