

# SHARE CART

## 52861

### Reduce hunger and waste with a New Age Share Cart.

Elevate any school share program with a New Age Share Cart! This cart comes in many colors, and features two locations for custom signage to encourage students to share their individually packaged foods, milk, juice, fruit, and more.

The cart comes with cold food pans that, when frozen, can hold food safely for 6-8 hours eliminating the need for ice! Heavy duty casters, a lightweight design, and a convenient push handle make this cart easy to maneuver.



HACCP compliant cold food pans **INCLUDED**.

Two locations for custom signage.

Top shelf designed to hold HACCP compliant cold food pan drop-ins. (pans included)

Push handle.

Slanted second shelf for easy access and storage.

Reinforced base shelf for miscellaneous storage.



Students can leave unwanted, unopened food and drinks in the Share Cart, where other students can help themselves.

**40%** of food is thrown out in America, yet **14 million** children go to bed and to school hungry.

Food waste in schools has increased due to the Federal School Lunch Program requiring students to take a certain amount of food— Even if they don't like it or aren't hungry.



**OPTIONAL** Cold Pan Shelf (#52918)

# SHARE CART

## 52861



52861NTBLUE

**NO  
ICE  
NEEDED**

Model No.	Size D - H - L	Ship Lbs.
52861*	23 1/4" x 70" x 32 1/4"	85
<b>Unit Without Top / Signage Header</b>		
52861NT*	23 1/4" x 34" x 32 1/4"	80

\* Must select color option.

Four 5" plate type casters, two swivel, two swivel with brake. All welded aluminum construction.

**HACCP compliant cold food pans included.**

Note: Poly food boxes, custom signs and any other accessories are not included and must be purchased by end user.

**Options Sold Separately: Must select color.**

- 52918 - Cold Pan Shelf -**  
Hinged, drop-down shelf built to hold 1/3-size cold pan.
- 52919 - Computer/Tablet Shelf -**  
Hinged, drop down shelf for a computer/tablet.

**• Color options:**

- **Red** - Add "RED" suffix to model #.
- **Orange** - Add "ORANGE" suffix to model #.
- **Yellow** - Add "YELLOW" suffix to model #.
- **Green** - Add "GREEN" suffix to model #.
- **Blue** - Add "BLUE" suffix to model #.
- **Purple** - Add "PURPLE" suffix to model #.
- **Black** - Add "BLACK" suffix to model #.

Note: Poly food boxes, custom signage and any other accessories are not included and must be purchased by end user.

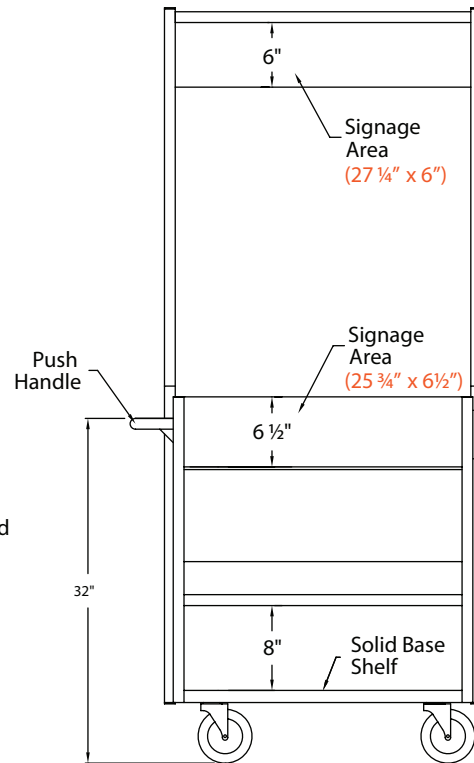
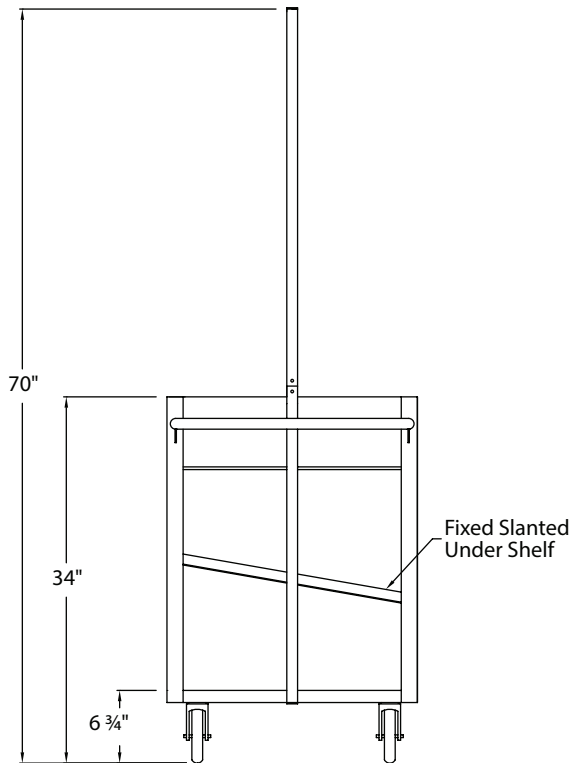
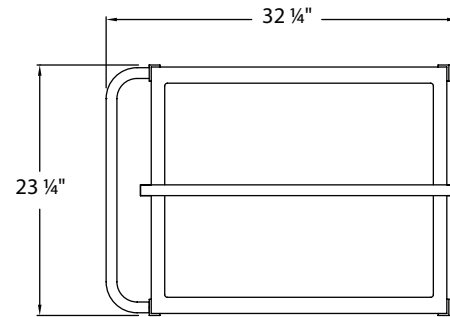

This information is for general sales and engineering use only. New Age Industrial reserves the right to modify or make changes at any time without notice to materials and specifications.

7-1-2025

Made in the USA

**NEW AGE  
INDUSTRIAL  
NEW AGE**  
NewAgeIndustrial.com | 800-2550-0104