

Job: \_\_\_\_\_

Item: \_\_\_\_\_

Quantity: \_\_\_\_\_

## Wet Produce Cart - Economy

This double deck cart moves product at a convenient, workable height from the floor. Removable drip pan helps keep things dry and clean.

- Framework is constructed out of 1¼" x 1¼" x .070" wall tubing.
- Removable drip tray is constructed out of .080" aluminum sheet.
- Handle is constructed out of 1" x 1" x .070" wall tubing.
- Equipped with four 5" platform type casters, two swivel and two rigid.
- Five-Year Guarantee against material defects and workmanship.
- Lifetime Guarantee against rust and corrosion.
- NSF Certified.



97126

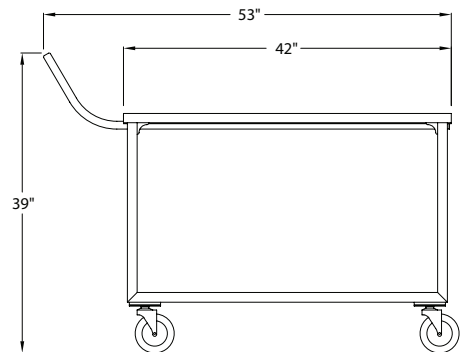
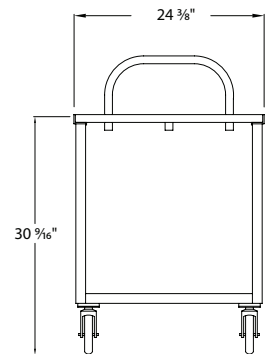

Model No	Size W-H-L	Weight Capacity	No. Casters	Top Shelf Height	Shelf Spacing	Ship Lbs.
<b>Cart w/ One (1) Removable Pan</b>						
97126	24 3/8" x 38" x 52"	700 lbs.	4	30"	20"	52

Above unit has removable pan on top shelf w/ heavy duty tubular base.  
 Four 5" platform type casters — two swivel (#C450) two rigid (#C460).

**Options:**

"B", "CL(B)", "PB" -- See catalog for details.

**Paper Towel Bracket** - Add "PTB" suffix to model #.

Distributed by:

*This information is for general sales and engineering use only. New Age Industrial reserves the right to modify or make changes at any time without notice to materials and specifications.*

