

Project: _____

Item: _____

Quantity: _____

Lifetime Series Dunnage Racks



The toughest Dunnage Racks on the market, these racks are built to last. All welded all aluminum design is great for keeping product organized and off the floor. Racks will hold up to a maximum of 5000 lbs.

- Constructed of Primary Grade Aluminum.
- Framework is constructed of 2" x 2" x .100" wall tubing.
- The legs are permanently sealed with welded aluminum caps.
- Lifetime Guarantee against material defects and workmanship.
- Lifetime Guarantee against rust and corrosion.
- NSF Certified.

★ Dunnage Rack

Model No.	Size W-H-D	Weight Capacity	Ship Lbs.
4004	20" x 12" x 36"	5000 lbs.	18
4005	20" x 12" x 48"	4000 lbs.	21
4006	20" x 12" x 60"	3400 lbs.	23
4008	24" x 12" x 36"	4000 lbs.	21
4009	24" x 12" x 48"	4000 lbs.	25
4010	24" x 12" x 60"	4000 lbs.	27
4027	30" x 12" x 48"	4000 lbs.	31
4065	36" x 12" x 48"	4000 lbs.	35

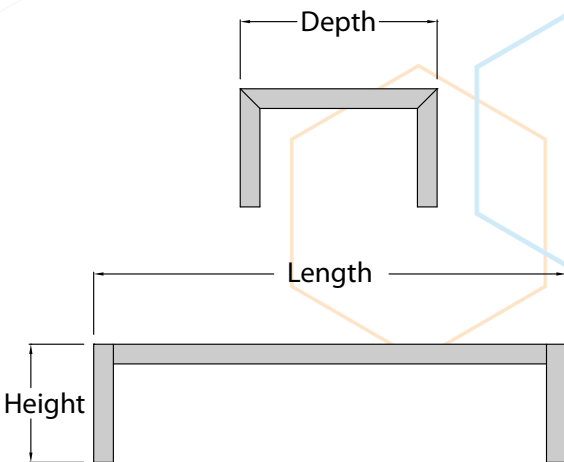

All LIFETIME SERIES products carry a LIFETIME Guarantee against rust and corrosion as well as a LIFETIME Guarantee against material defects and workmanship.

New Age Industrial Corp., Inc. || NewAgeIndustrial.com || Made in the USA

PO Box 520 • 16788 US Hwy 36 • Norton, Kansas 67654 || Phone: (800) 255-0104 • (785) 877-5121 || Fax: (877)-877-7687 • (785) 877-2616

This information is for general sales and engineering use only. New Age Industrial reserves the right to modify or make changes at any time, without notice, to materials and specifications.