

Project: _____

Item: _____

Quantity: _____

Raised Picking Pallet



53960



Raised Picking Pallets facilitate organized product picking. Ergonomic raised, solid platform for easier loading and unloading. Order Picker secures to the Raised Picking Pallet with 2" x 4" replaceable wood clamp blocks, allowing the order picker to firmly grip the platform.

- One-Year Guarantee against material defects and workmanship.
- Lifetime Guarantee against rust and corrosion.

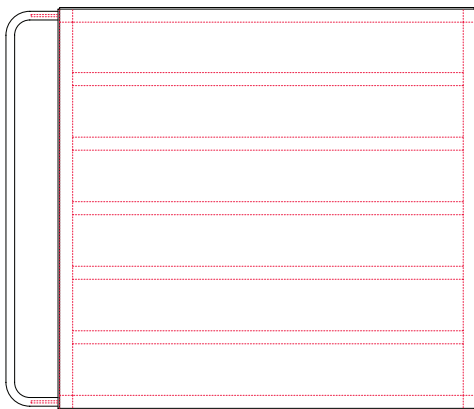

► Raised Picking Pallet

Model No.	Lift Type	Size W-H-D	Net Lbs.	Ship Lbs.
Stationary				
53999	Universal	46 1/2" x 36" x 54 3/16"	189	217
Mobile				
53960	Universal	46 1/2" x 36" x 54 3/16"	190	222

Mobile unit equipped with four 5" plate type casters; two swivel, two rigid.
 Deck Area = 46" x 48"; Designed to hold 40" x 48" pallets.
 Weight Capacity = 1,200 lbs.
 Custom Sizes Available.

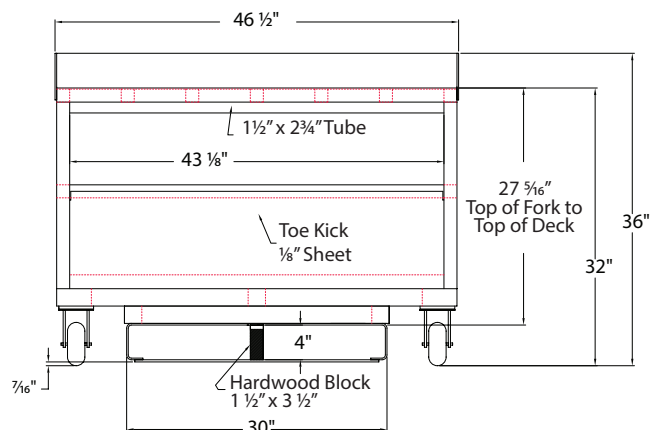
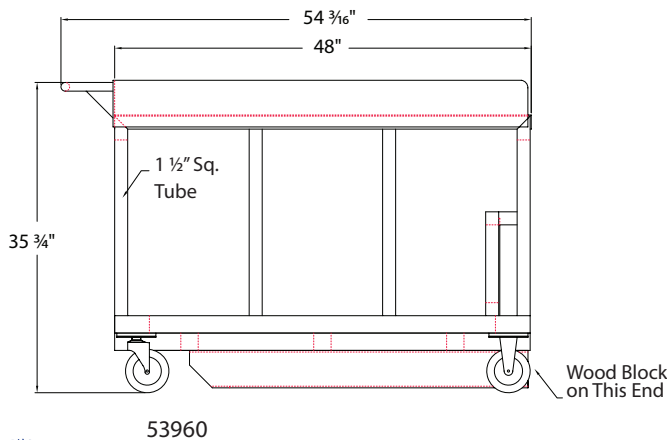

New Age Industrial Corp., Inc. || NewAgeIndustrial.com || Made in the USA

PO Box 520 • 16788 US Hwy 36 • Norton, Kansas 67654 || Phone: (800) 255-0104 • (785) 877-5121 || Fax: (877)-877-7687 • (785) 877-2616

This information is for general sales and engineering use only. New Age Industrial reserves the right to modify or make changes at any time, without notice, to materials and specifications.