

Project: \_\_\_\_\_

Item: \_\_\_\_\_

Quantity: \_\_\_\_\_

## Mobile Accessory Rack



95640

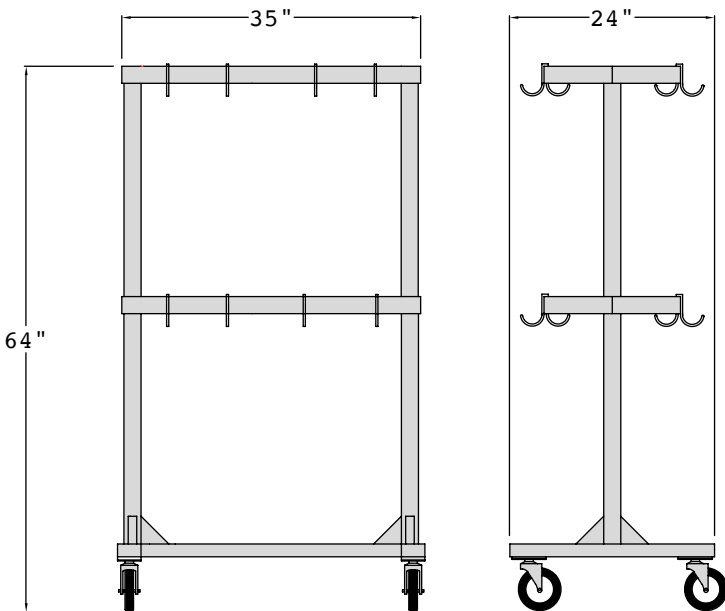

### Easy, Hands-On Access

Operational efficiency at its finest. Sixteen double hooks. Keep pots, pans, lids and utensils readily accessible at all stages of food preparation and storage.

Easily maneuvered around the prep area, this unit is equipped with four, 5" platform type heavy duty swivel casters Non-marking wheels prevent scuff marks and roll smoothly...Even on tile floors.

- All welded unit with all seams sealed constructed of Primary Type 6463-T5 aluminum alloy.
- Square tube uprights and base are welded in an "I" shape with heavily gusseted base.
- Sixteen hooks of 1/4" diameter, 304 stainless steel are adjustable along rack arms.
- Equipped with four 5" platform type swivel casters with non-marking wheels.
- Five-Year Guarantee against workmanship and material defects.
- Lifetime Guarantee against rust and corrosion.
- Made in the USA.

Model No.	Size W-H-L	Ship Lbs.
95640	24" x 64" x 36"	57



New Age Industrial Corp., Inc. || [NewAgeIndustrial.com](http://NewAgeIndustrial.com) || Made in the USA

PO Box 520 • 16788 US Hwy 36 • Norton, Kansas 67654 || Phone: (800) 255-0104 • (785) 877-5121 || Fax: (877)-877-7687 • (785) 877-2616

This information is for general sales and engineering use only. New Age Industrial reserves the right to modify or make changes at any time, without notice, to materials and specifications.