

Soiled Skewer transport cart with removable drip pan that lifts out for cleaning.

- Upper frame consists of 1" x 3" rectangular tube, with drip pan support frame welded in place.
- Base is constructed of 1 1/4" sq. tube outer frame, 3/8" thick caster plates welded to frame, rungs on base frame for extra storage.
- Removable drip pan to catch debris from skewers.
- Primary Grade Aluminum; All welded construction.
- Five-Year Guarantee against workmanship and material defects.
- Lifetime Guarantee against rust and corrosion.
- Made in the USA.
- Custom Manufactured in accordance with NSF standard 2 and "Custom NSF" marked for Costco.



53938PAN - Replacement Pan



Model No.	Size D-H-L
53938CST	16" x 31 3/8" x 36 1/8"
53938PAN	Replacement Pan

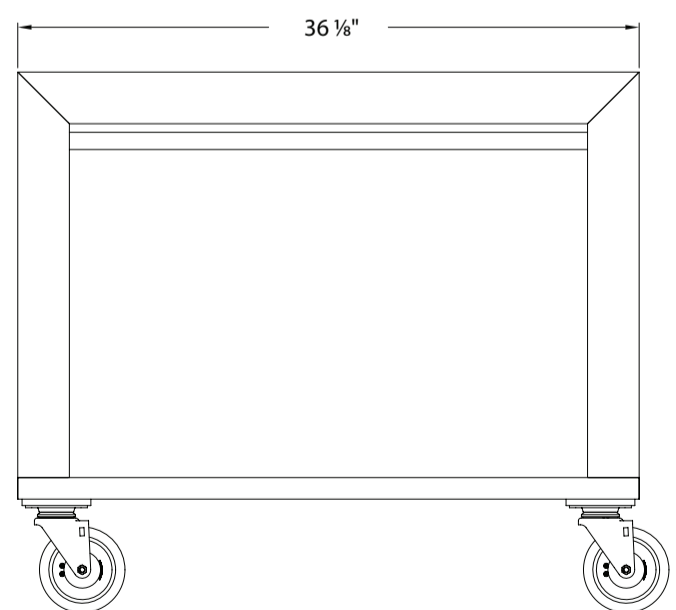
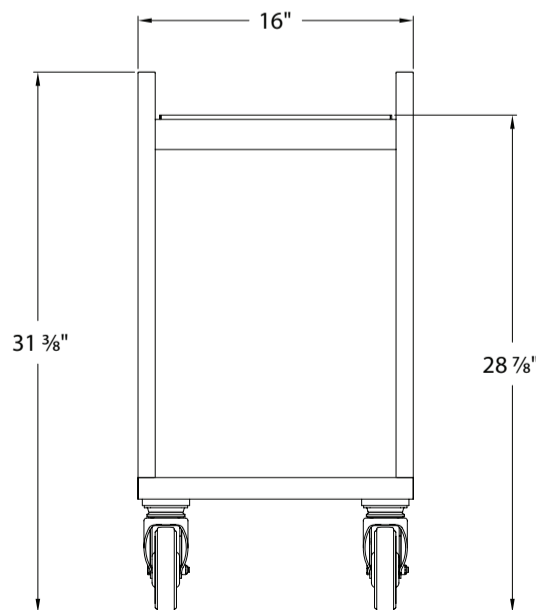
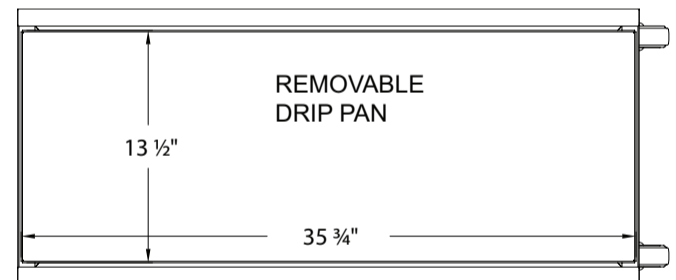

January 2025

This information is for general sales and engineering use only. New Age Industrial reserves the right to modify or make changes at any time without notice to materials and specifications.

