

Designed to accommodate Hobart FP250 Food Processor and ToteAll 2000 lugs.

- Uprights consist of 1 1/4" x 1 1/2" rectangular tube, with lug supports of 1 1/4" x 1 1/4" x .100" wall angle welded in place.
- Base is constructed of 1 1/4" x 1 1/2" rectangular tube. 3/8" thick caster plates are welded to the base frame to accept platform casters.
- Solid top has retaining tab to secure the food processor in place.
- Equipped with four non-marking polyurethane 5" plate type stainless steel swivel casters, all with brakes.
- Primary Grade Aluminum; All welded construction.
- Five-Year Guarantee against workmanship and material defects.
- Lifetime Guarantee against rust and corrosion.
- Made in the USA.
- Custom Manufactured in accordance with NSF standard 2 and "Custom NSF" marked for Costco.

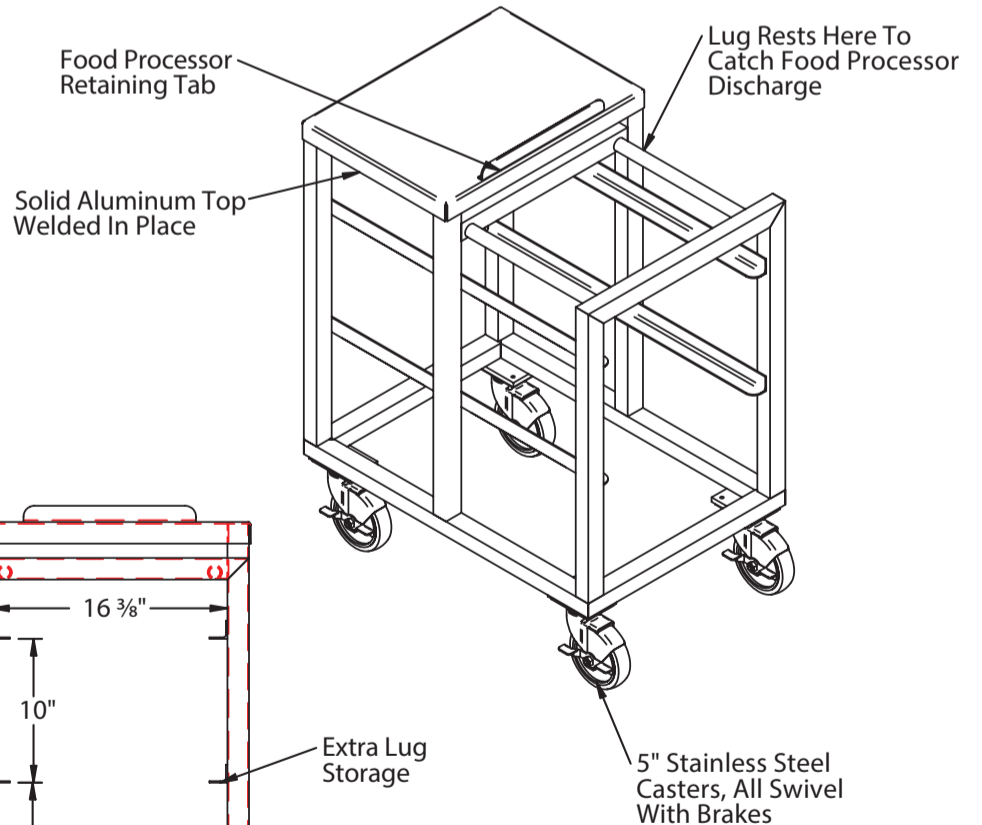
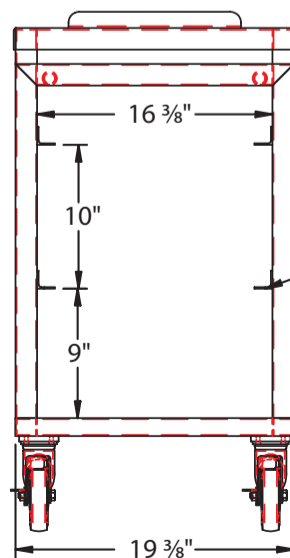
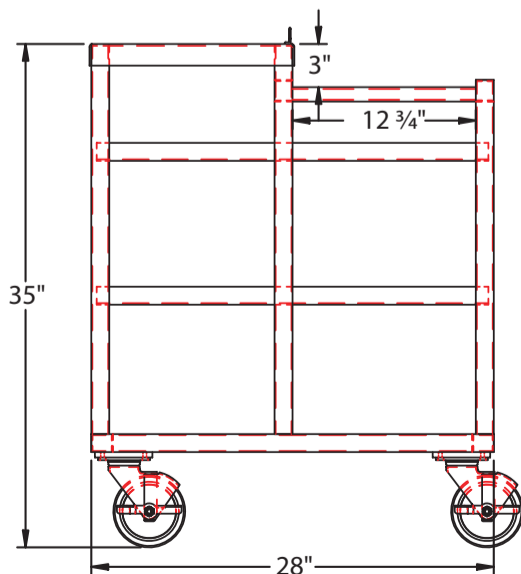
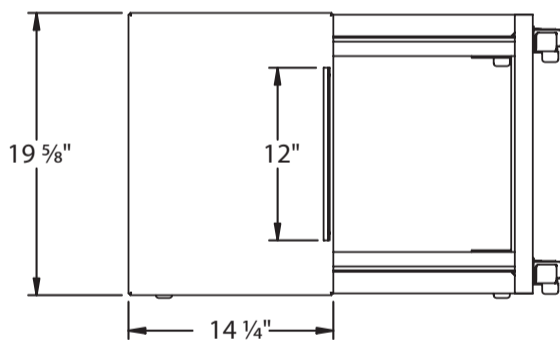
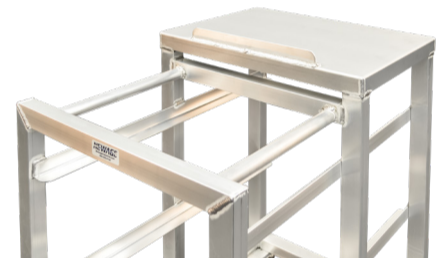

Model No.	Size W-H-D
53943CST	28 1/8" x 35" x 19 5/8"

Feb 2025