

These lug dollies are ideal for bulk food transporting. They accept the standard lugs (16"W x 8½"H x 25"L).

- Framework is constructed out of 1¼" x 1¼" x .070" wall tubing. Angle runners are 1¼" x 1¼" x .100" wall angle.
- Equipped with four non-marking polyurethane 5" plate type stainless steel swivel casters.
- Five-Year Guarantee against workmanship and material defects.
- Lifetime Guarantee against rust and corrosion.
- Made in the USA.
- Custom Manufactured in accordance with NSF standard 2 and "Custom NSF" marked for Costco.

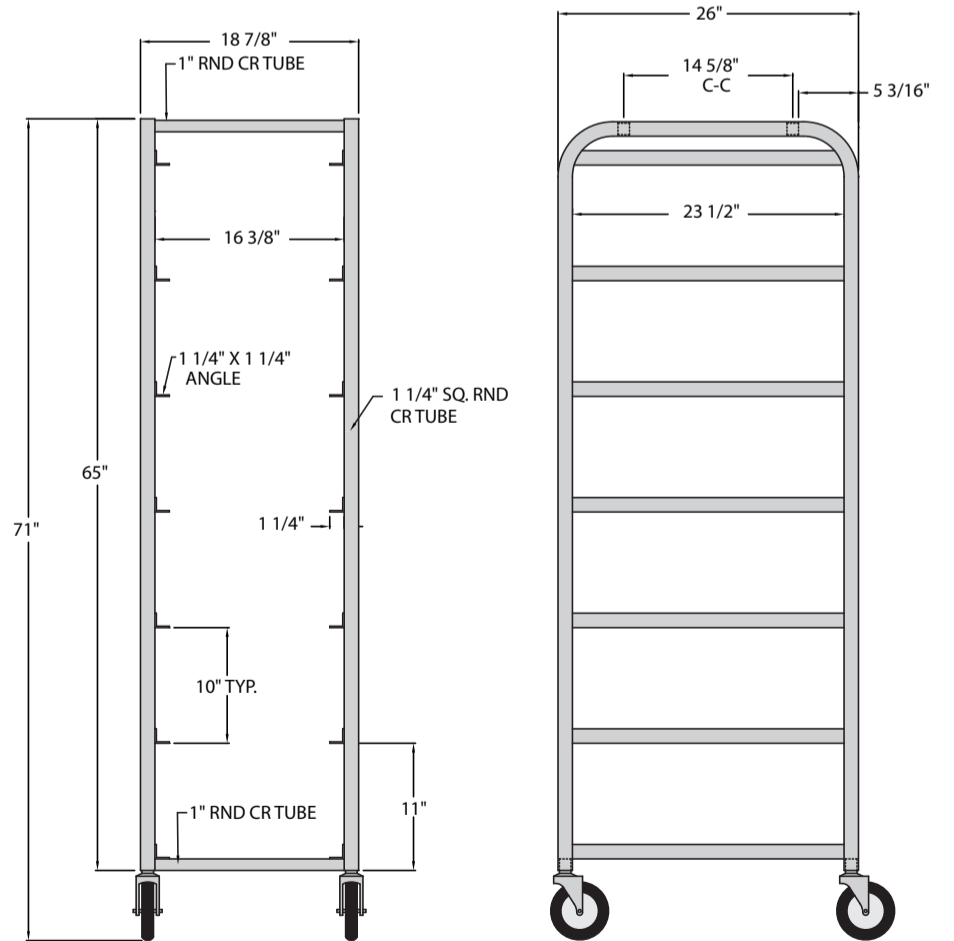

Model No.	Lug Cap.	Size W-H-D	Lbs.
6263CST	6	18¾" x 71" x 26"	25

Four 5" swivel type stem casters (C482SS) - No brakes.