

General storage and movement of trays and pans.

- Heavy duty, high tensile, extruded aluminum. Type 6063-T5 alloy.
- Slides are 1¼" x 1⅝" x .100 extruded aluminum angle welded to frame.
- Vertical and horizontal frame members are 1" x 1" x .070 extruded aluminum tubing. All welded unit.
- Gussets of 1½" x 1½" x ⅝" thick angle are welded to the inside angles (bottom side) where horizontal cross bracing meets vertical uprights.
- Equipped with four, platform type, 5" diameter stainless steel wheels, full swivel design. Wheel material is non-marking polyurethane.
- All-welded construction.
- Five-Year Guarantee against workmanship and material defects.
- Lifetime Guarantee against rust and corrosion.
- Made in the USA.

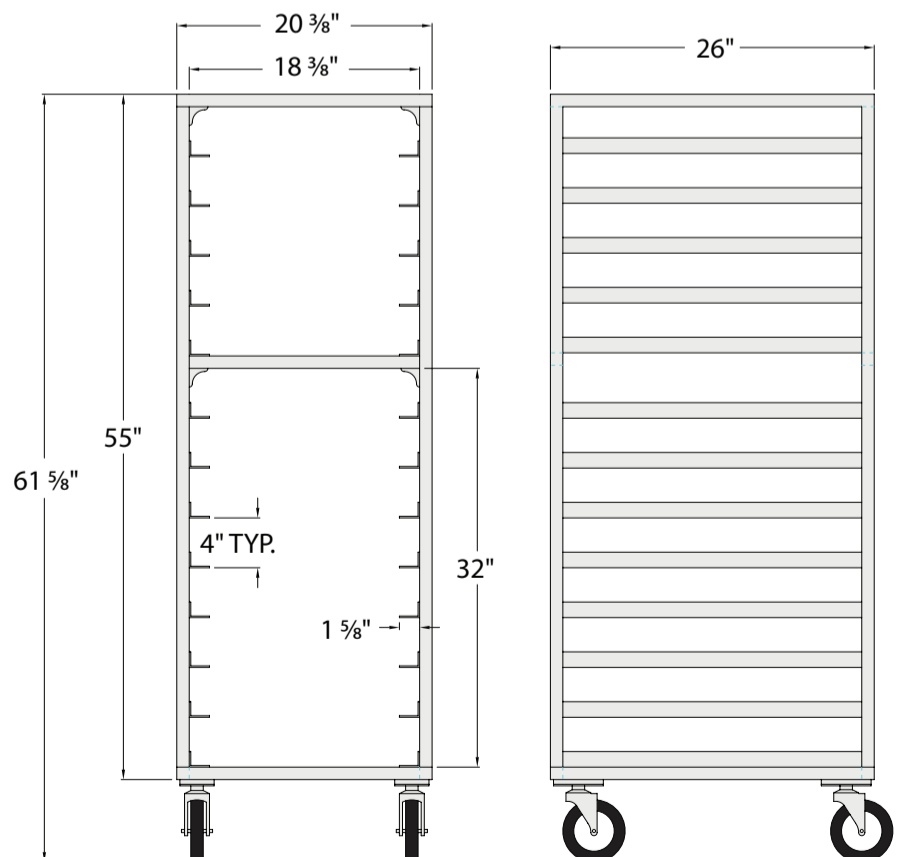

Model No.	Size W-H-D	Pan Capacity	Runner Spacing	Ship Lbs.
End Loading Rack				
95768CST	20⅜" x 61⅝" x 26"	13	4"	46

Four 5" platform type stainless steel swivel casters (#C450SS).