

- This Equipment Stand is constructed of 1½" tube throughout with a .080" aluminum sheet top and undershelf.
- Equipped with four 5" plate type swivel casters; stainless steel rig, with brake.
- Five-Year Guarantee against workmanship and material defects.
- Lifetime Guarantee against rust and corrosion.
- Made in the USA.
- Built in accordance with NSF.

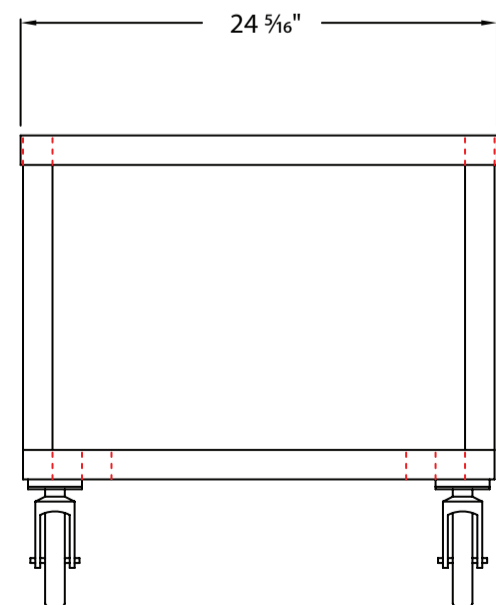
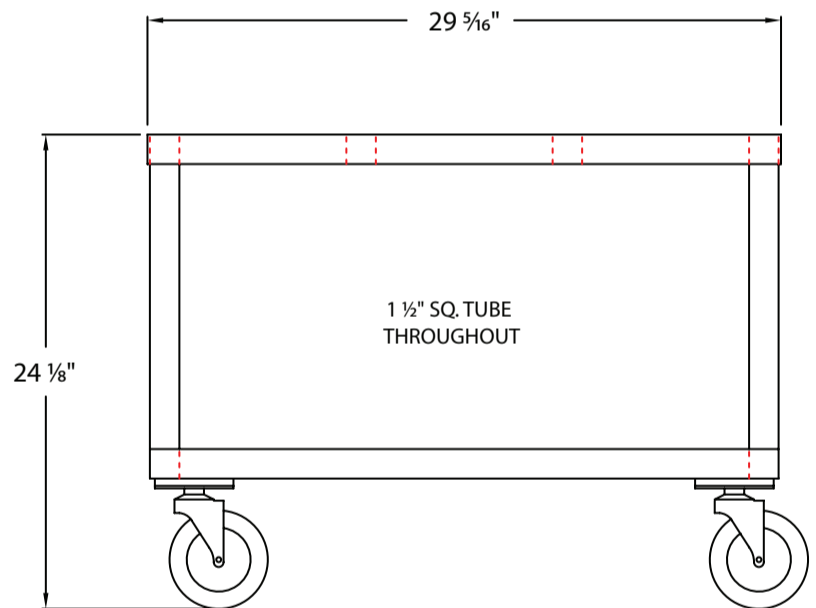

NSF Certified - Custom

Model No.	Size W-H-D	Ship Lbs.
96465CST	29 ⁵ / ₁₆ " x 24 ¹ / ₈ " x 24 ⁵ / ₁₆ "	34